



REPAIR MANUAL

ZF 45 C	version 10; 001
ZF 45 C - Walter	version 002
ZF 45 C - Toyota	version 11; 003
ZF 63 C	version 07; 001
ZF 88 C	version 001

Cod. 310.01.0056d

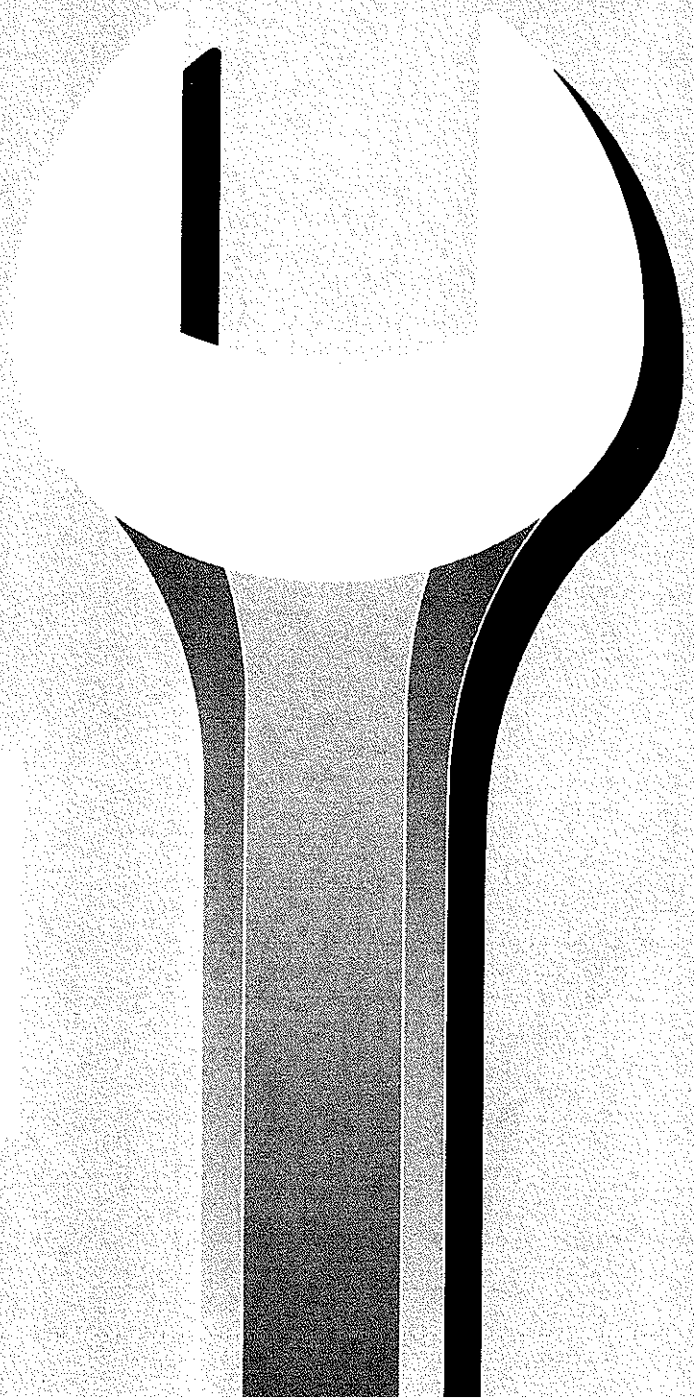

TABLE OF CONTENTS

Introduction	2	SECTION V: PLAY ADJUSTMENT	22
SECTION I: GENERAL DATA	2	1. Reverse clutch clearance	22
1. Transmission Set-up	2	2. Forward clutch clearance	23
2. Consumable goods	3	3. Input shaft play	24
3. Measuring Tools	3	4. Output shaft bearing play	25
4. Standard Tools and Fixture	3	SECTION VI: TIGHTENING TORQUES	26
SECTION II: SPECIAL TOOLS	4	SECTION VII: FUNCTION TEST	26
SECTION III: DISASSEMBLY PREPARATION	5	1. Filling up with transmission fluid	26
Introduction	5	2. Check fluid level	26
1. Preliminary operation	5	3. Function test	27
2. Housing disassembly	5	4. Shifting pressure ZF 45C / 63C / 88C	28
3. Input shaft	8	5. Lube oil delivery ZF 45C / 63C / 88C	29
4. Forward clutch housing disassembly	9	SECTION VIII: TROUBLESHOOTING	30
SECTION IV: ASSEMBLY	12	SECTION IX: AUTOMATIC TRANSMISSION FLUID	33
Introduction	12	SECTION X: SPARE PARTS LIST AND EXPLOSION DRAWINGS	35
1. Input shaft	12		
2. Housing assembly	15		
3. Complementary operations	18		
4. Oil pump	21		

INTRODUCTION

This manual gives specific instructions for the proper repair on ZF 45C / 63C / 88C model transmissions.

Please follow the procedures carefully to insure quality service.

ZF HURTH MARINE recommends to read the manual completely before starting with repairs, as some of the procedures described are rather complex.

Along with standard tools, ZF HURTH MARINE recommends the use of special tools, necessary to perform repairs correctly. The special tools are available through your local ZF HURTH MARINE dealer.

This manual is based on the technical information at the time of printing. The manual has been checked carefully in order to avoid errors. However ZF HURTH MARINE is not liable, for any misrepresentations, errors of description or omissions.

Modifications on future manuals may be introduced without prior notice.

The following international symbols are used in this service manual.

 **WARNING: THIS SYMBOL WARNS OF POSSIBLE PERSONAL INJURY.**

 **CAUTION: This symbol warns of possible damage to transmission.**

SECTION I: GENERAL DATA

1. TRANSMISSIONS SET-UP

The main components of the HSW Marine Transmissions are:

- | | |
|--------|---|
| Item 1 | two-piece aluminum die cast |
| 1.1 | oil filter |
| 1.2 | oil dipstick |
| 1.3 | pump |
| Item 2 | gears |
| 2.1 | input shaft with forward clutch pack assembly |
| 2.2 | planet gear carrier assembly |
| Item 3 | control valve |

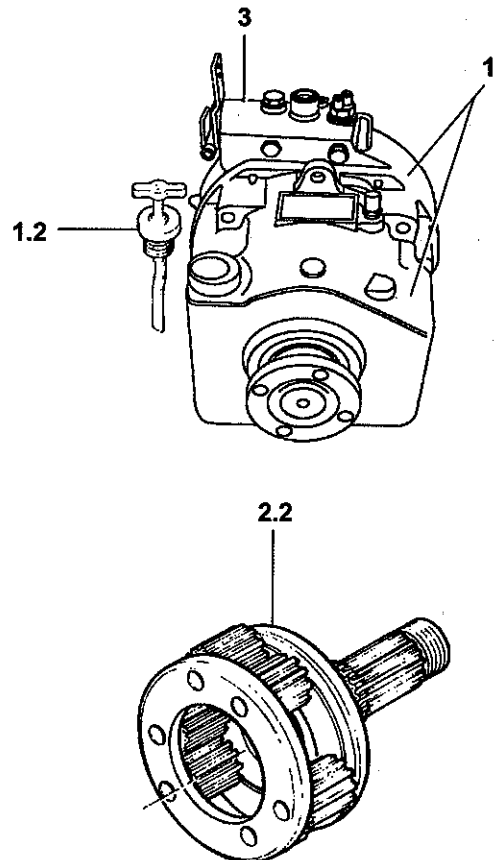
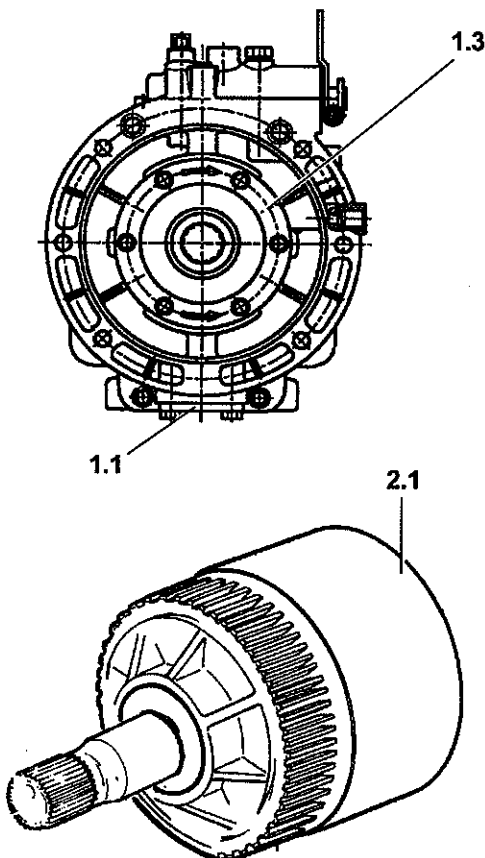

2. CONSUMABLE GOODS

For cleaning:

Cold cleaner such as benzine, trichloroethane or Loctite fast cleaner No. 7063.



WARNING

Keep detergents away from your skin, do not drink and do not inhale their vapors! Always wear protective gloves and safety glasses!

Note accident prevention rules!

For assembly:

- Loctite 245 for securing output flange on spline
- Loctite 574 on the outside diameter of the seals and on mating surfaces
- Grease: Klüber STABURAGS NBU 30, for radial shaft seals
- ATF Fluid - 1.75 Liters (1.85 US qts)
[see ATF fluid list chap. IX]

3. MEASURING TOOLS

Dial indicator gauge with arm-type support

Range 0 - 1" (0 - 25 mm) in 0.0005" (0.01 mm) increments

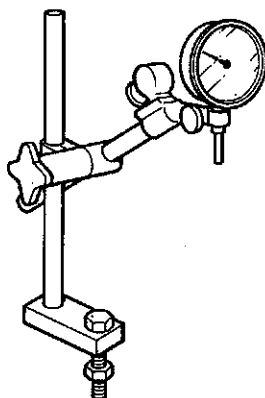

Caliper

Range 0 - 6" (0 - 150 mm) in 0.0005" (0.01 mm) increments

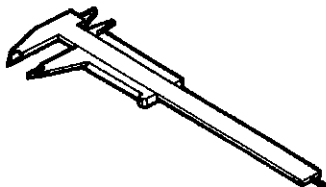

1/2" tool bar

working edge within 0.0002" per 12"

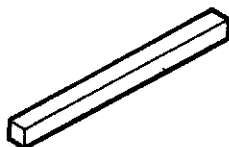

4. STANDARD TOOLS AND FIXTURE

Wrench

for hexagon bolts (8 mm, 13 mm, 14 mm, 17 mm, 19 mm, 22 mm)

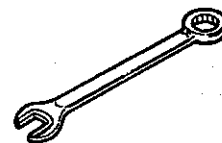

Allen wrench

(5 mm, 6 mm, 8 mm)

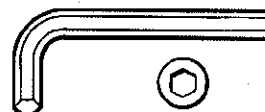

Hexagon drive socket wrench

(13 mm, 17 mm, 19 mm)



Torque wrenches

Ranges:

-20 lb in -200 lb in (5 Nm - 65Nm)

-15 lb ft - 100 lb ft (30 Nm - 150 Nm)



Plastic hammer (1000 g) (24 oz)

sturdy screwdriver



- Pullers

blind hole bushing (planetary gear assembly) range 1/4" to 1 3/4" 4 lb slide hammer

output flange range 3 1/2" to 5 1/2" 5 ton; 3 - jaw

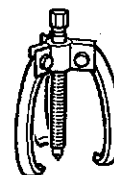

No. 2 Pry bars

1/2" stock



Snap ring pliers

sizes: 9" (shaft diameter 1 1/2" to 3 1/2")

10" (bore diameter 1 1/2" to 4")



SECTION II: SPECIAL TOOLS

It is assumed that all standard tools, such as, torque wrenches, open-end wrenches, Allen Keys and extractors, are available.

All fixtures for pressing in and out should be used in conjunction with a hydraulic or manual press. Ident numbers are also stock reference numbers.

Mandrel

Oil pump seal, (Id. No. 500493)

P/N 978.45.0022.0



Mandrel

Bushing, (Id. No. 500494)

P/N 978.45.0023.0



Mandrel

Control valve oil seal, (Id. No. 500495)

P/N 978.45.0024.0



Mandrel

Input shaft rollers bearing, (Id. No. 500496)

P/N 978.45.0025.0



Mandrel

Forward clutch circlip, (Id. No. 500497)

P/N 978.45.0026.0

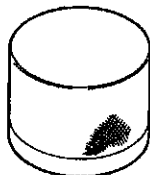

Mandrel

Input shaft ball bearing (Id. No. 500498)

P/N 978.45.0027.0



Mandrel

Output shaft ball bearing, (Id. No. 500499)

P/N 978.45.0028.0



Plate

Housing support, (Id. No. 500500)

P/N 978.45.0029.0

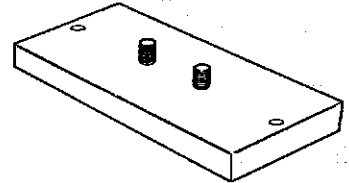

Plug

Forward clutch, (Id. No. 500501)

P/N 978.45.0030.0

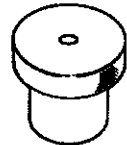

Wrench

Output flange, (Id. No. 500446)

P/N 978.40.0002.0

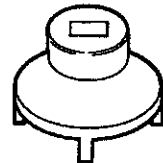

Antirotation bracket

Output flange, (Id. No. 500502)

P/N 978.45.0031.0

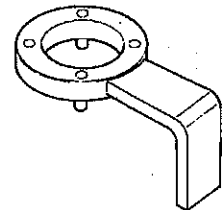

Clamp ring

Input shaft play, (Id. No. 618582)

P/N 219.354.3



SECTION III: DISASSEMBLY PREPARATION

INTRODUCTION

Clean the transmission thoroughly on the outside before disassembly.

The repair area should be clean and well lighted.

ZF HURTH MARINE recommends using a stand (P.N. 500500) for aiding in assembly and disassembly.

1. PRELIMINARY OPERATION

- 1.1 Remove the breather valve (22) and oil dipstick (26). Clean the breather with suitable cleaner, allow to dry and coat with oil.

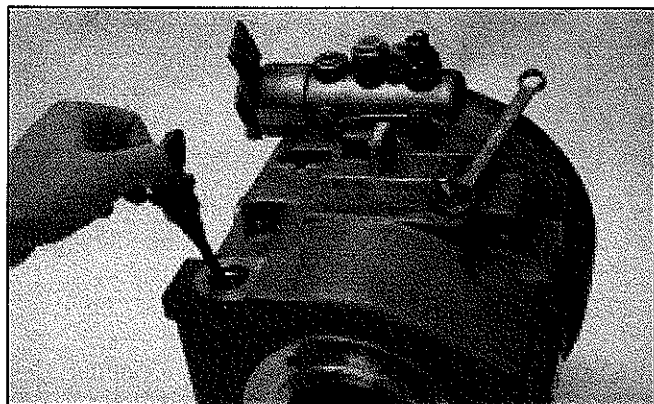

- 1.2 Screw off bolts (6) and washers (10), remove the filter cover (5), seal (4) and filter element (3). Inspect seal for wear and replace if necessary. Clean the filter element with suitable cleaner.



WARNING

Position a container to pick up the oil flow.

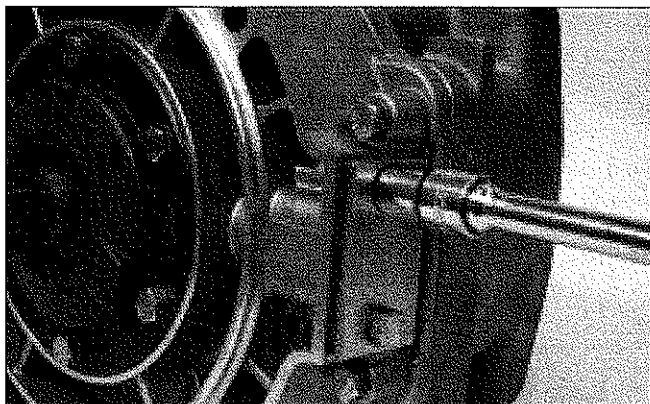

2. HOUSING DISASSEMBLY

- 2.1 Position the marine gearbox on the housing support (P.N. 500500).

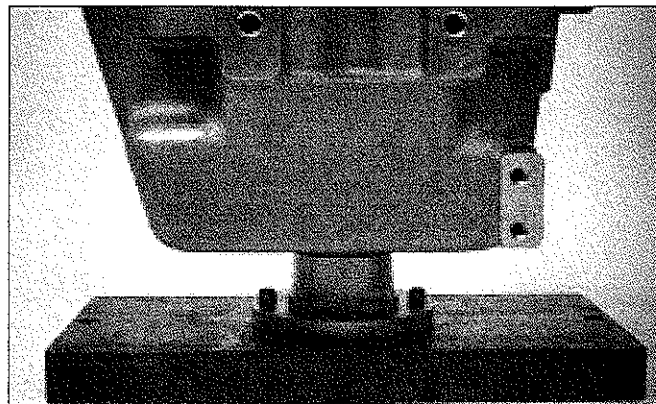

- 2.2 Screw off bolts (6) and washers (10). Remove the pump cover assembly (34). Inspect sealing ring (1) and O-Ring (33); inspect for wear and replace if necessary.

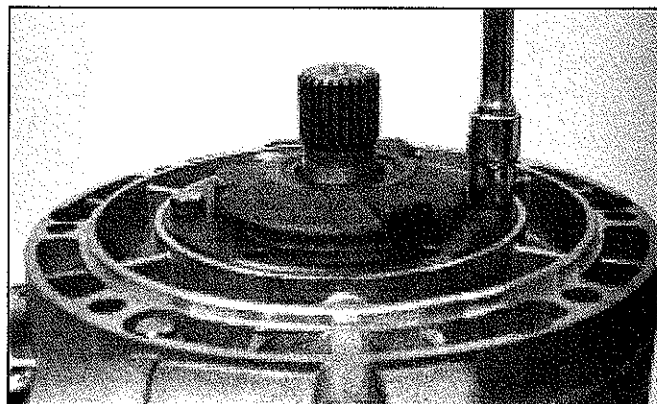

- 2.3 Remove the rotor pump from the shaft. If it needs to be replaced, the complete cover assembly (34) has to be replaced.

NOTE: Pump gear should be installed the same side down as removed.

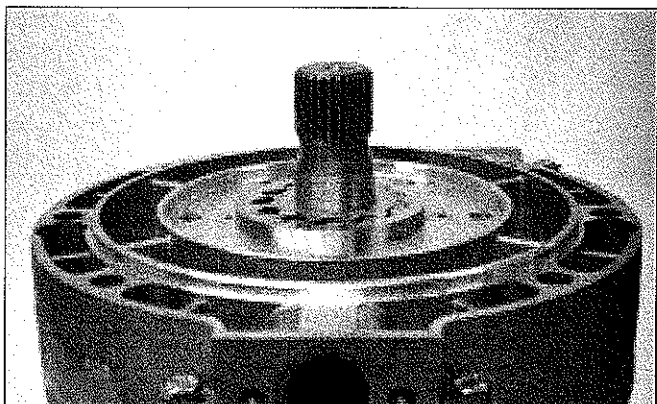

2.4 Using pliers remove the key (28) from shaft.

NOTE: Take note of the position of the key.

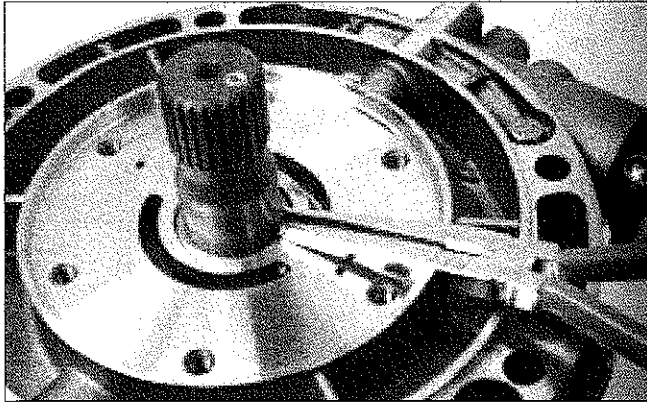

2.7 Remove the cover (35).

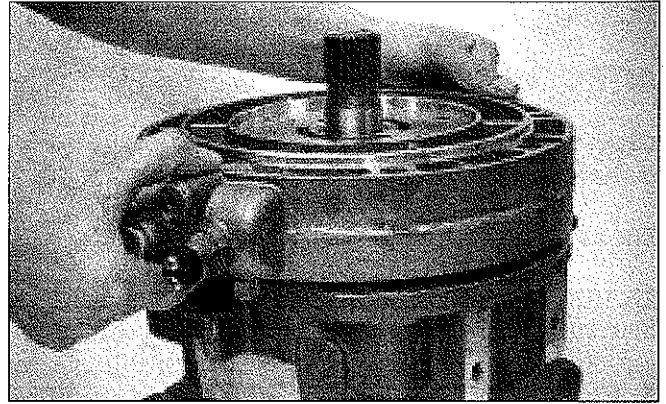

2.5 Screw off bolts (7), (8) and washers (10).

2.8 Remove reverse clutch first outer disc (63).

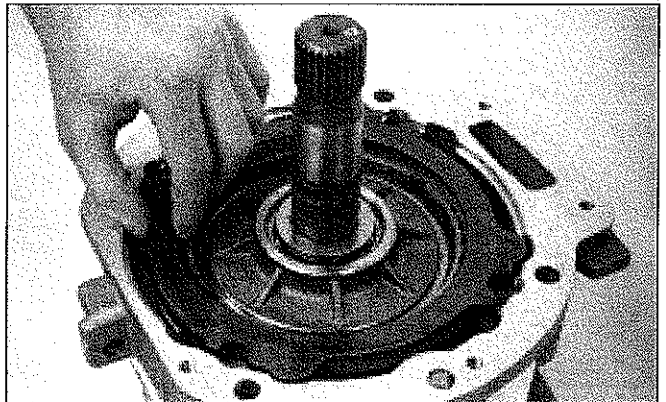
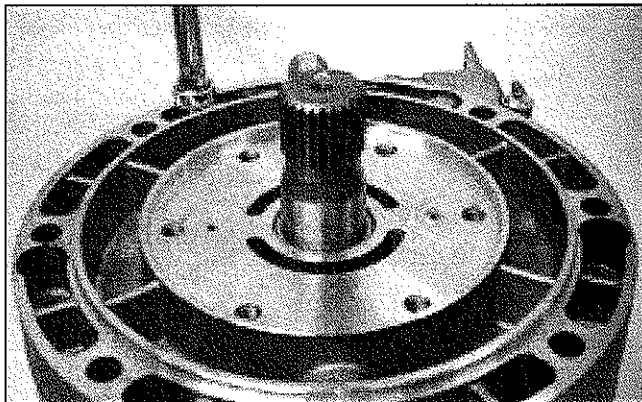

2.6 By tapping with a soft hammer separate the cover (35) from the housing (36).

2.9 Remove springs (58).

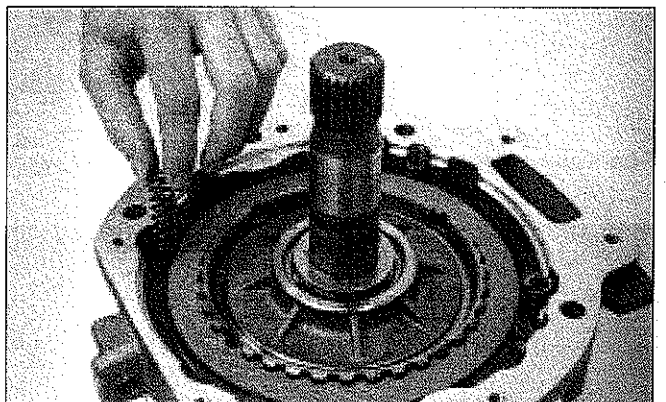
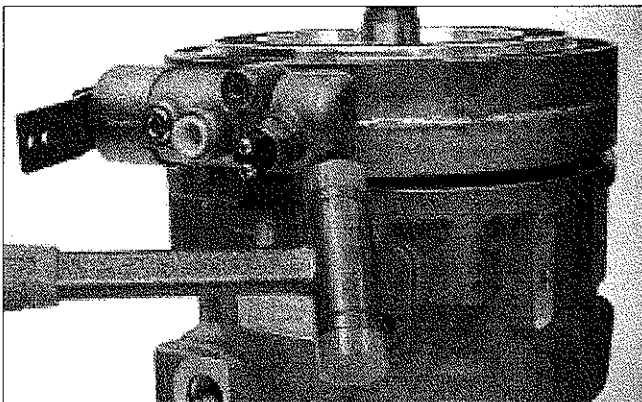

2.10 Remove inner disc (62), outer disc (63), inner disc (62), the last outer disc (63) and if present shims (64),(65).

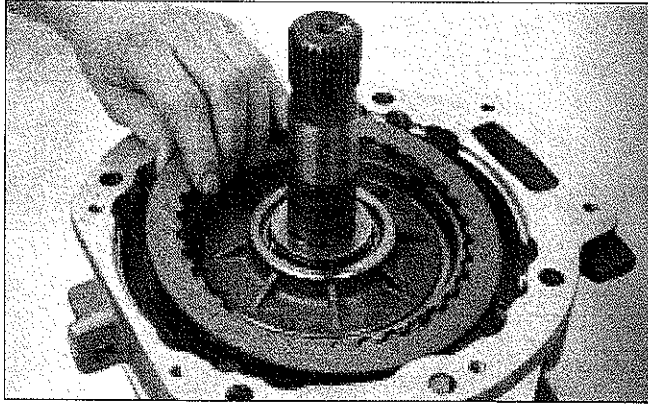

2.11 Pull out the shaft and forward clutch assembly.

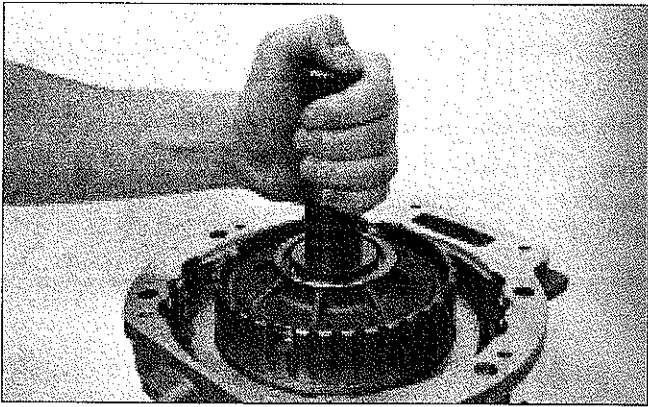

2.12 Remove thrust washer (45) which is remained on the planet gear carrier assembly and (with standard puller) bushing (46).

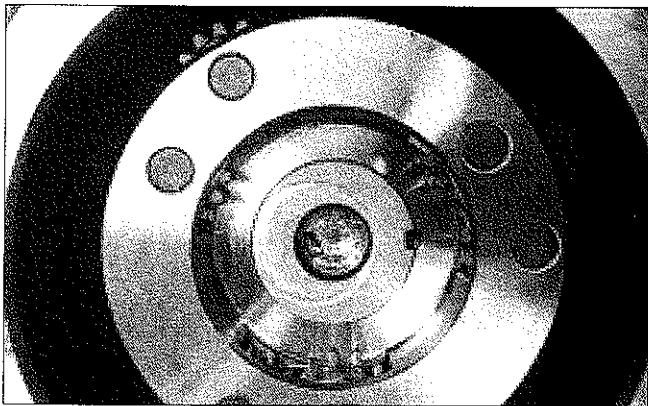

2.13 Turn the housing upside down. Using the tool P.N.500446 loosen nut (72); stop the output flange (66) from turning using tool P.N.500502. Discard O-Ring (71) and replace with a new one.

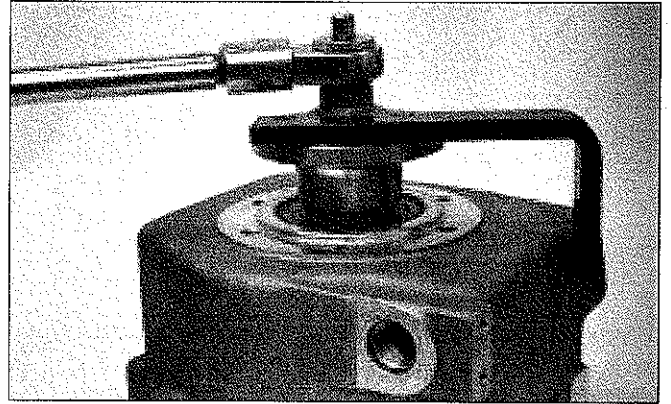

2.14 Remove flange using appropriate puller.



WARNING

[see type page 3].

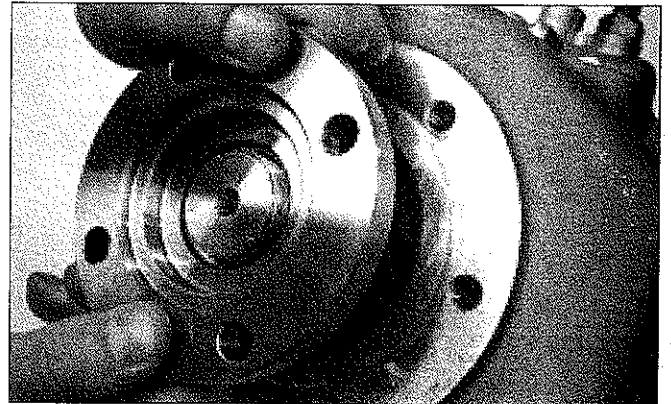

2.15 With a soft hammer disassemble the output shaft. Driving it out from the housing.

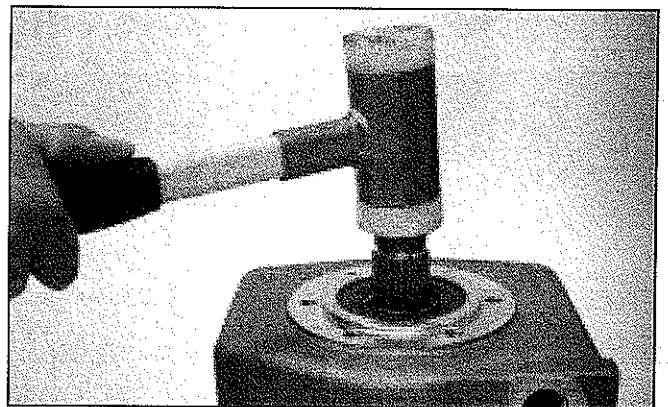

2.16 **Don't disassemble the output shaft.**
If it's necessary to replace it, ask for complete gear carrier assembly (38).

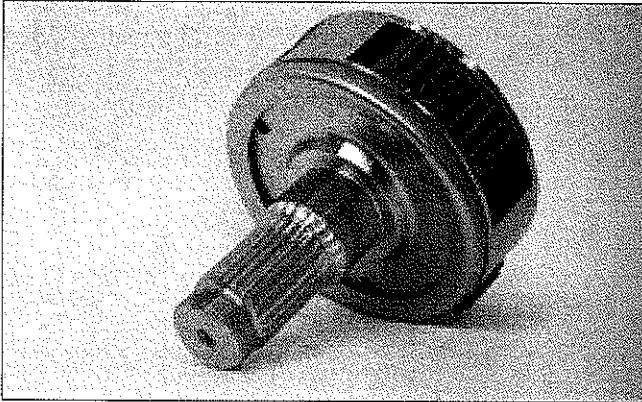

3.3 With pliers remove the circlip (44).

NOTE: Take note of the position of the circlip (44).

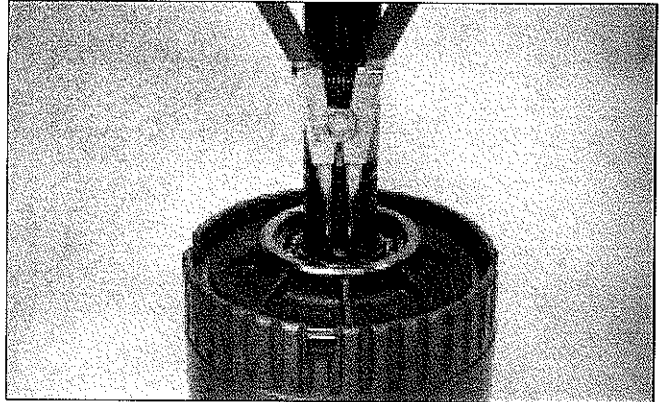

3. INPUT SHAFT

3.1 Remove piston rings (39) from the input shaft (37).

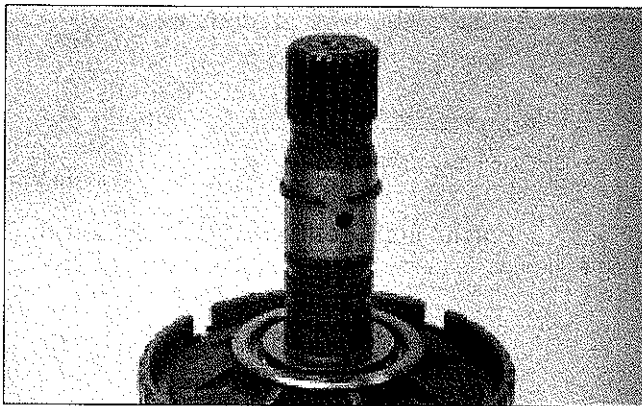

3.2 Remove spacer (42b), needle bearing (42a), other spacer (42b) and shims (75-76).

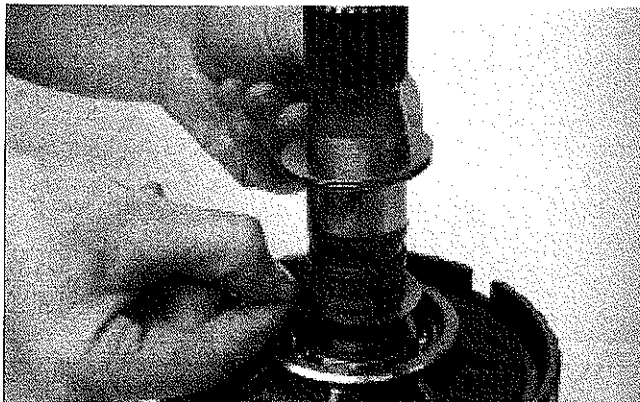

3.4 Support the ring gear allowing room for the input shaft with gears to come out bottom side.

NOTE: Pressing on splined end of shaft disassemble it from the clutch housing.

This operation will damage the bearing.

Use a press with:

distance: 200 mm (8 inches)
min. force: 2000 kg (4400 lbs)

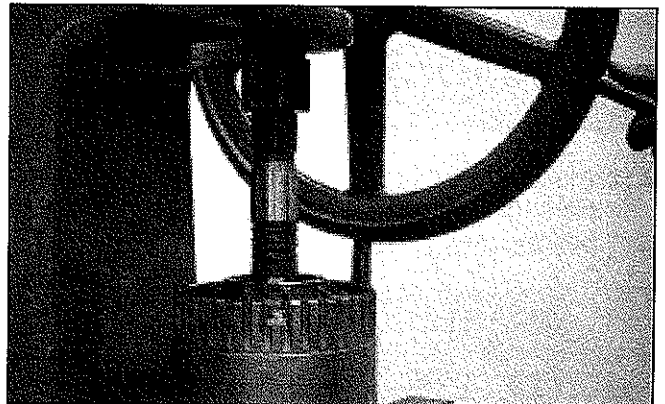

3.5 Remove piston rings (40) from the input shaft (37).

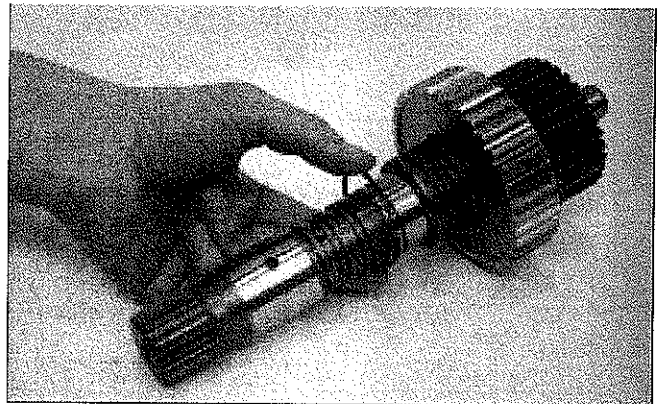

4. FORWARD CLUTCH HOUSING DISASSEMBLY

4.1 Remove circlip (48).

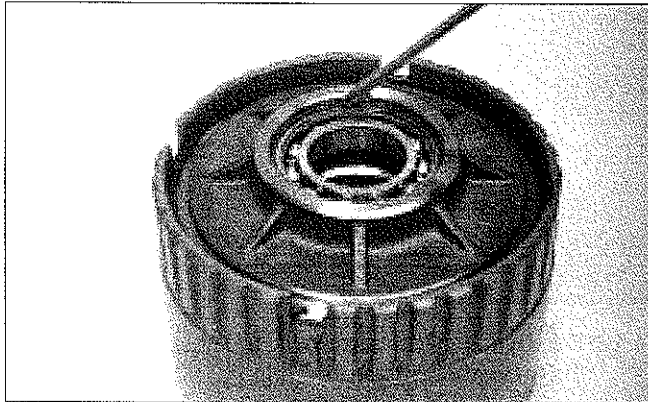

WARNING

4.2 With a screwdriver remove the circlip (50).

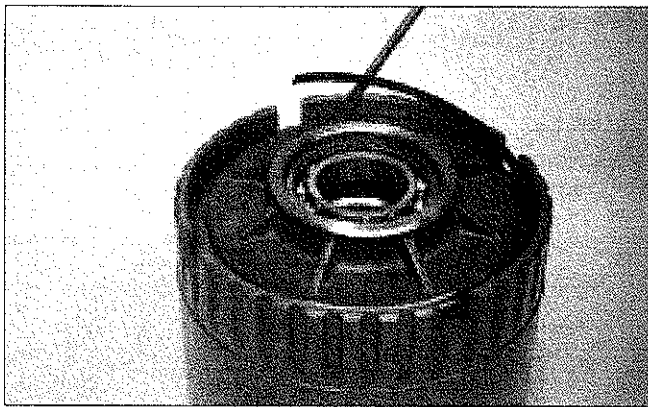

4.3 Support clutch housing flat on to a work bench. Separate ring gear support (47) from the ring gear (49).



4.4 Remove forward clutch inner (60), outer (61) shims (73) (74) and end disc (59).

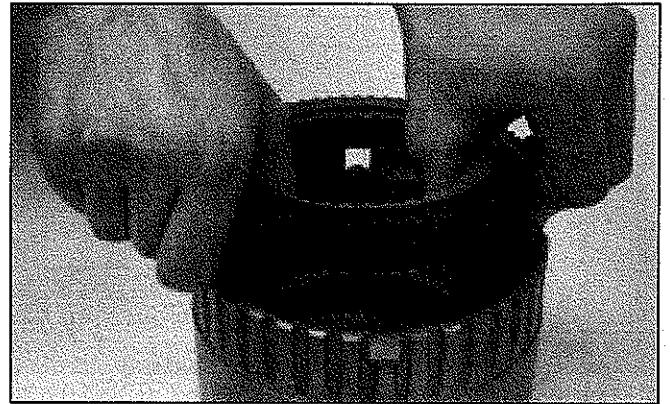

WARNING

4.5 Remove circlip (55), cup springs (54).

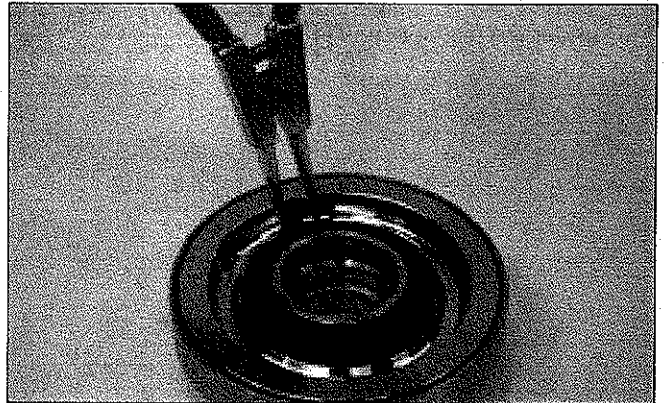

Remove only if defective.

4.6 With a tool P.N.500498 drive out ball bearing (43) which has to be discarded and replaced with a new one.

4.7 Introduce air with tool P.N. 500501 to push out the piston (51).

The piston can also be removed by gently tapping on the outer diameter of the housing with a soft hammer.

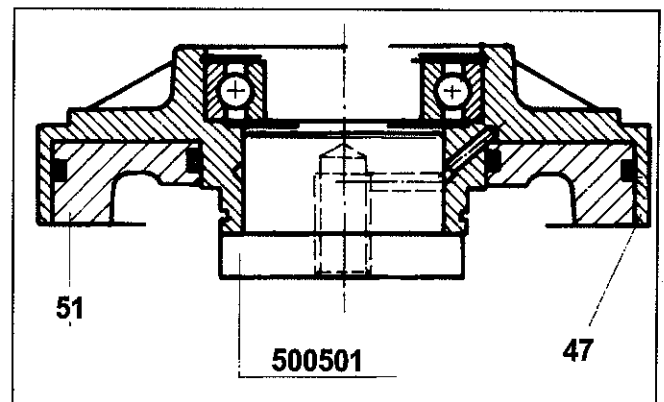

4.8 Remove O-Rings (52), (53) from the piston (51).

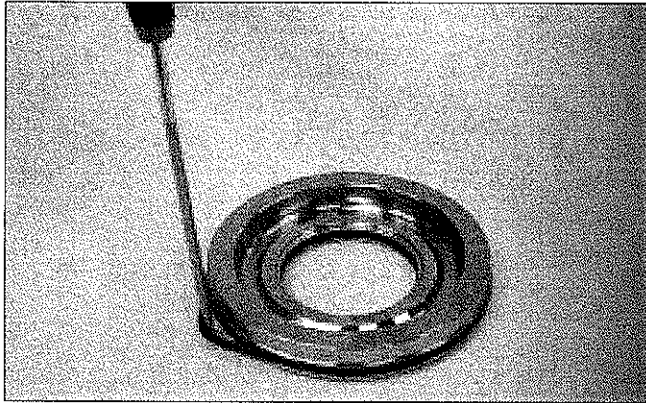

4.11 Remove O-Rings (57) from piston (56).

NOTE: Replace O-Rings (33, 57) if disassembled.

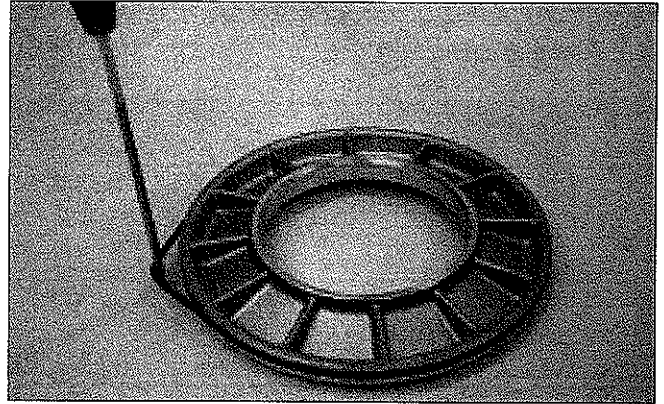

4.9 Inject air through the indicated hole, to remove the piston (56). The hole is located on the upper circular surface of the housing cover (clutch piston side) just under the piston screw (18).

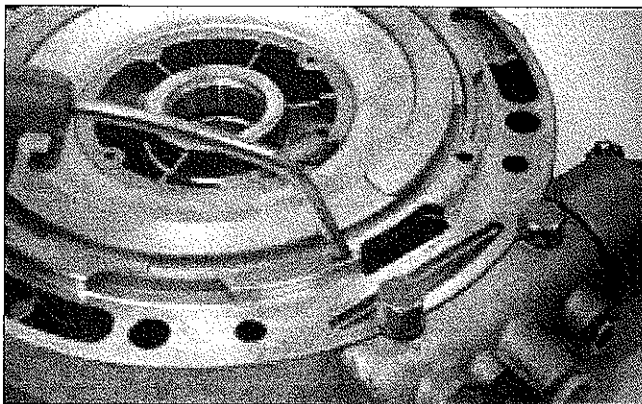

4.12 Remove the stop screw (17) and position screw (18), the two washers (13), the spring (20) and the ball (21).

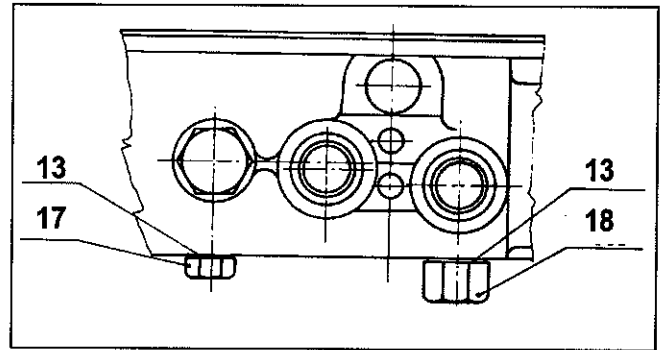

4.13 Remove the neutral safety switch (15), the plugs (12, 14), spacer (16), ball (21) and washer (19).

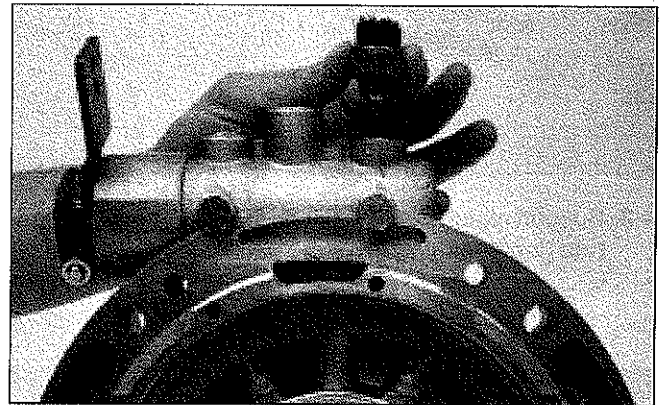

4.10 Remove the O-Ring (33) from cover (35).

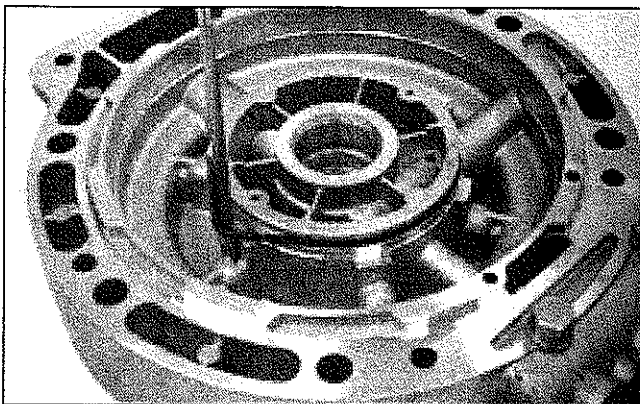

4.14 Using two screwdrivers pull out the distributor shaft (24), the distributor shaft seal (23) will come out together.

Remove seal ring (23) from the spool valve (24).

NOTE: 1 - Take note of the position of the seal ring.
2 - Replaced the seal ring if disassembled.



Don't disassemble the distributor shaft (24), if it's necessary to replace it use the complete group.

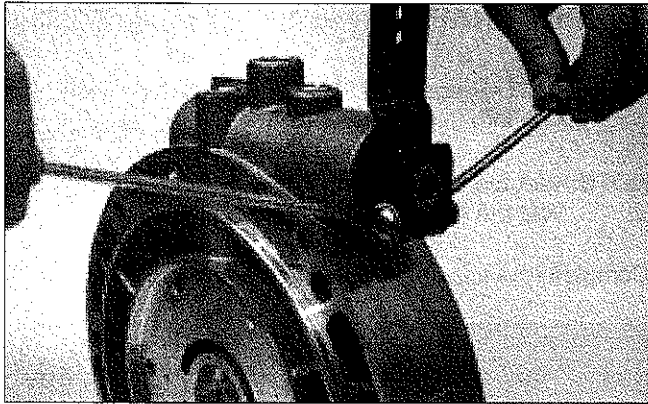

4.15 By striking with a soft hammer remove needle bearing (41).

Only if bearing is defective.

To do it properly support the cover allowing room for the needle bearing to come out bottom side. Stick a screw driver/punch into the internal edge of the cage and tap gently with a soft hammer in a criss cross pattern.

NOTE: This operation will damage the bearing.



WARNING

The improper use of screwdriver / punch can damage the cover. After having removed the bearing check for scratches on the cover.

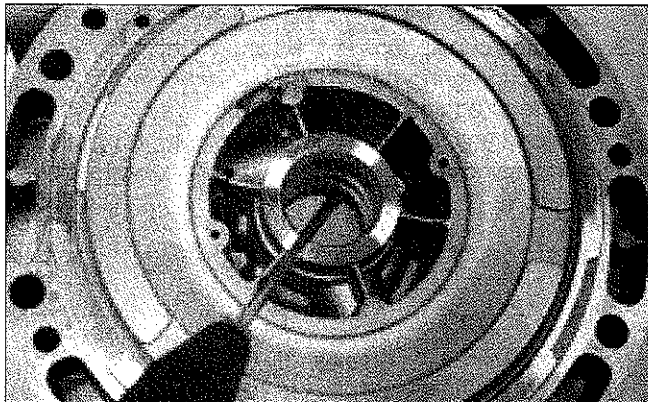

4.16 Remove sealing ring (1) and O-Ring (33) from pump cover (34).

NOTE: This operation will damage the sealing ring. Take note of the position of the seal ring.

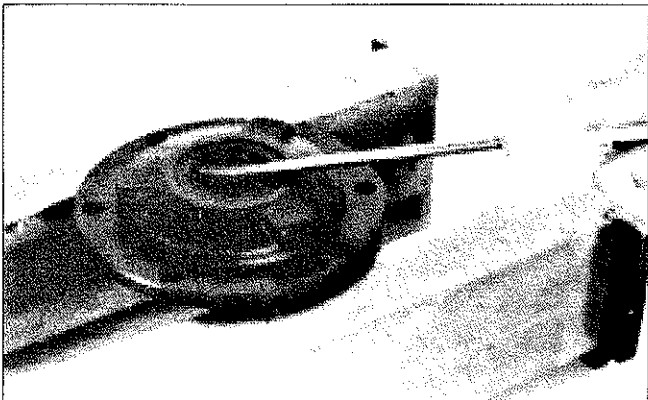

4.17 Remove baffle (29).

With a screwdriver take out an end of the baffle from the groove on the housing.

By gripping and rolling up the baffle take it out from the housing.

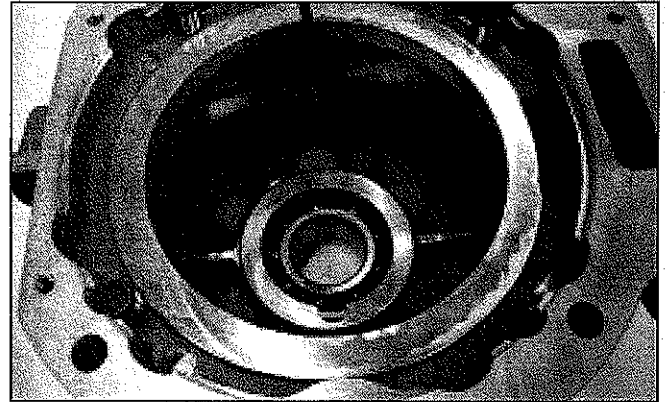

NOTE: ZF 45C VERS. TOYOTA 11 ONLY

Two additional baffles (30) and (31) and pin spacer (32) are present.

4.18 Remove output sealing ring (2).

NOTE: This operation will damage the oil seal.

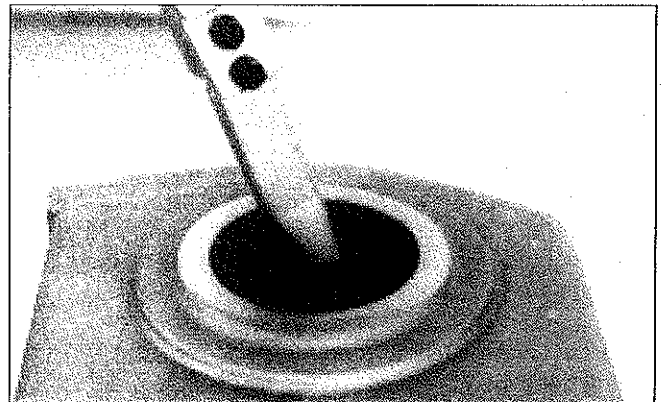

4.19 Remove circlip (70).

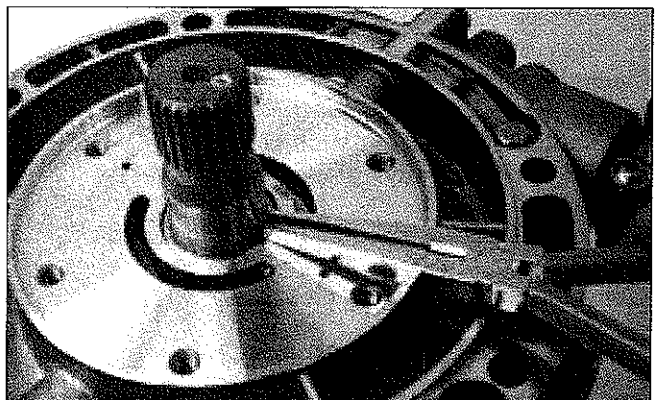

4.20 Support housing (36) flat on a press, press out bearing (67), then remove shims (68) (69).

NOTE: This operation will damage the bearing.

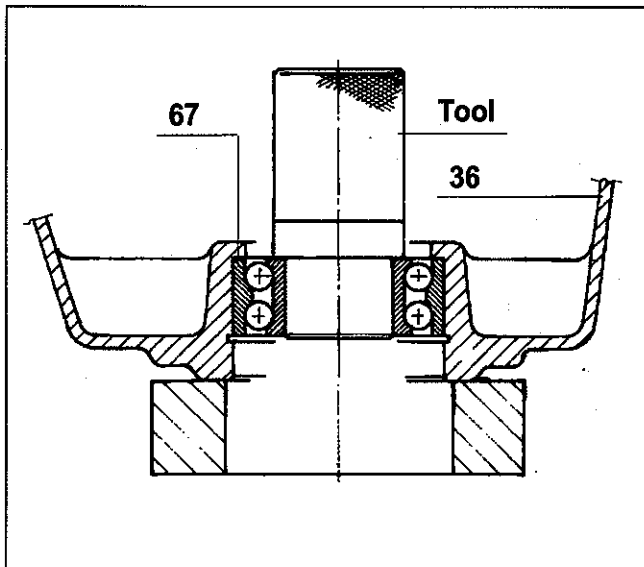

1. INPUT SHAFT

1.1 Install O-Rings (52) (53) on the piston (51). Insert the piston into the input bell (47).

NOTE: Wet the O-Rings with ATF.
Wet the mating surfaces with ATF.

Complete the assembly with a soft hammer.

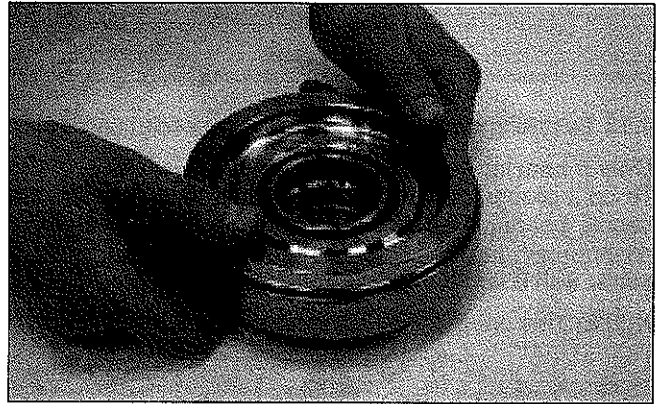

1.2 Position cup springs (54) as shown in figure. First cup spring has to be installed with the bigger diameter against the piston. Second and third cup springs have to be installed in succession with their bigger diameters against each other.

SECTION IV: ASSEMBLY

INTRODUCTION

A well-lighted work area that is free from dirt and chips, will facilitate the work considerably.

ZF HURTH MARINE recommends to use a swivelling stand, described in the disassembly section to aid in the assembly.

Thoroughly clean all mating surfaces from any loctite or gasket material.



**Cleaners and solvents can be toxic and harmful without proper ventilation.
Use caution when using such cleaners.
Always wear protective gloves and glasses!**

The next assembly procedure requires the following:

- A hydraulic or mechanical press.

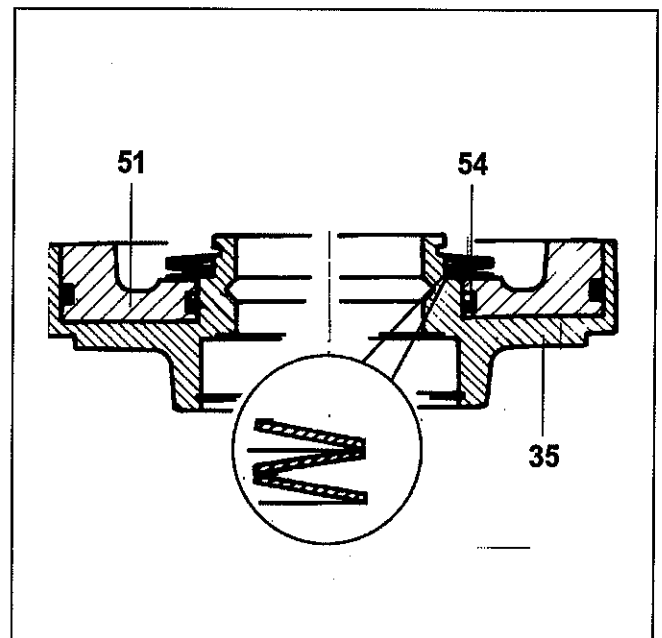

1.3 Position the circlip (55).

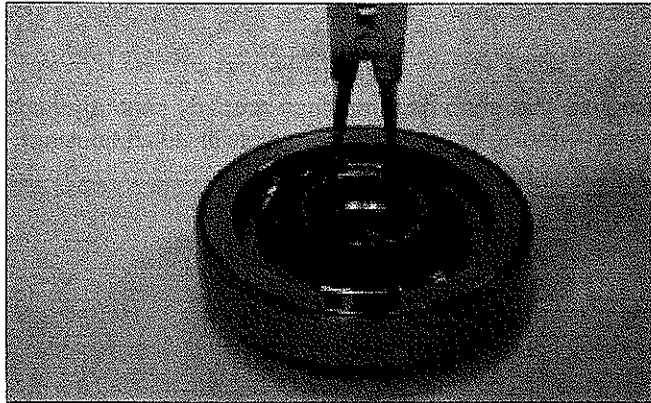

1.4 With tool P.N. 500497 compress the cup springs. Be sure of their alignment.

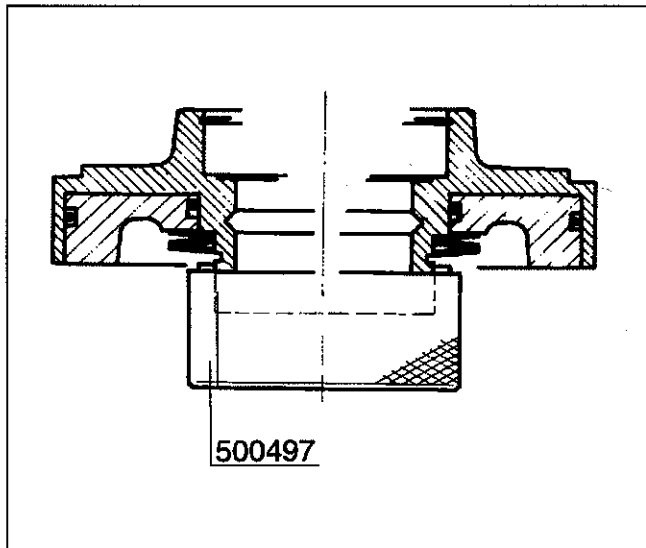

1.5 Install the piston rings (40).

NOTE: Coat sealing rings with grease or Petroleum Jally.

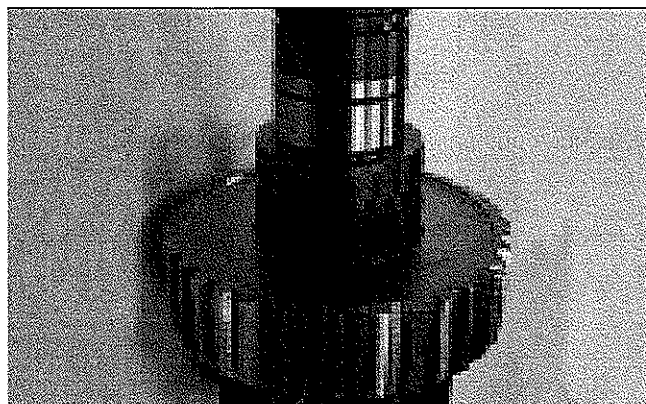

1.6 Insert end disc (finished side up) (59), shims (73 - 74) and alternatively outer clutch disc (61) and inner clutch disc (60).

NOTE: To set correct play see item 2 page 23. Clutch discs have to be coated with ATF.

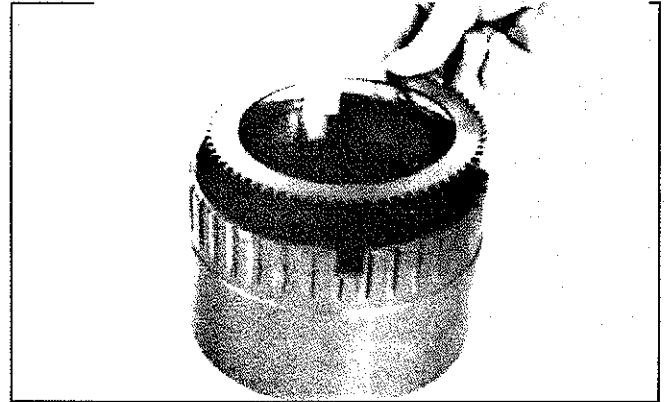

1.7 With tool p.n. 500498 and a suitable support press the ball bearing (43) into the ring gear support (47).

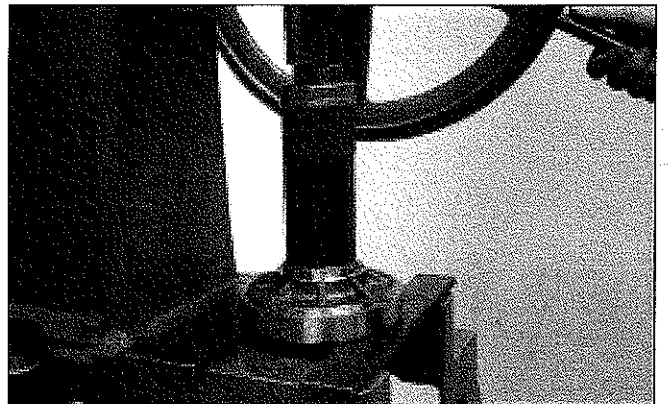

1.8 Insert the circlip (48).



Be sure that snap ring has been properly seated (check circlip opening to be not close to slots in clutch housing).



1.9 Press the forward clutch housing (47) on the input shaft (37).

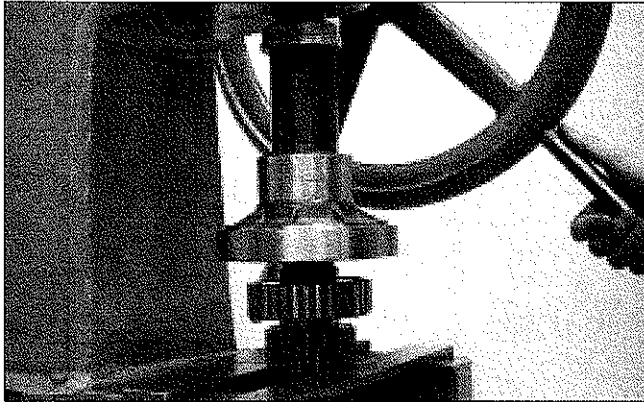

1.10 Install the circlip (44).

NOTE: Check carefully correct position of the circlip (44).

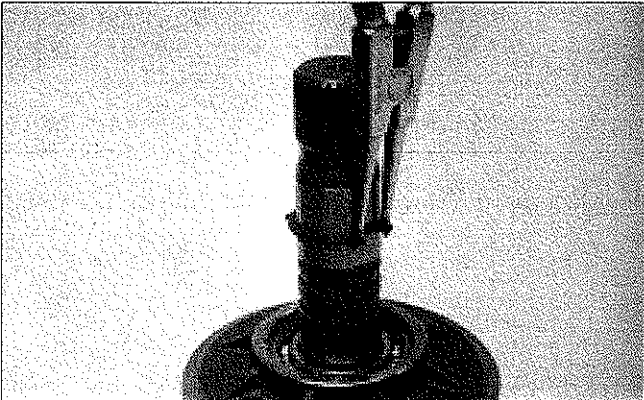

1.11 Turn up side down the ring gear (49) and place it on a suitable support, allowing the shaft go down completely.

Insert the input shaft (37) into the ring gear (49) allowing the inner clutch discs to be driven by the disc carrier.



1.12 Install the circlip (50).



WARNING

Be sure that snap ring has been properly seated (check circlip opening to be not close to slots in clutch housing).

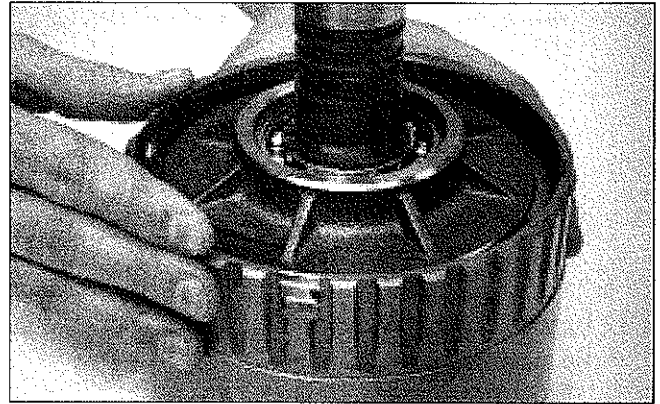

1.13 Install onto input shaft (37) the seal rings (39).

NOTE: Install seal rings (39) with openings in opposite positions.



1.14 Insert shims (75, 76) between circlip (48) and thrust washer (42).

NOTE: To set correct play see item 3 pag. 24.



- 1.15 With toll P.N. 500499 and a suitable support press ball bearing (67).
Add shims (68, 69) max bearing play:
0,1 mm (0.0039 in)

NOTE: To set correct play see item 4 page 25.



- 1.16 Install snap ring (70).

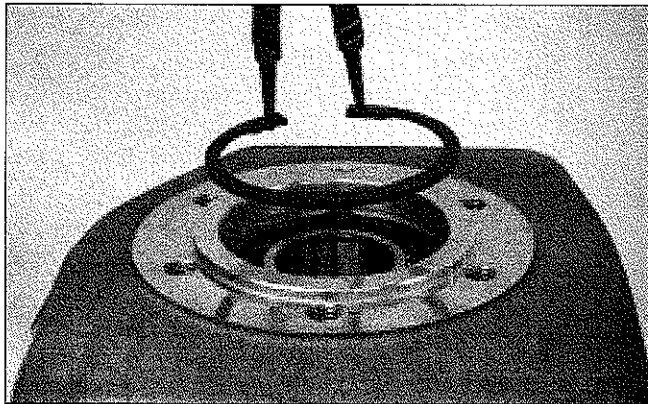

2. HOUSING ASSEMBLY

- 2.1 With tool P.N. 500499 install sealing ring (2).

NOTE:

- Use Loctite P.N. 574 between housing and sealing ring.
- Fill internal lips of sealing ring with high quality grease (for ex. Klüber STABURAGS NBU 30).

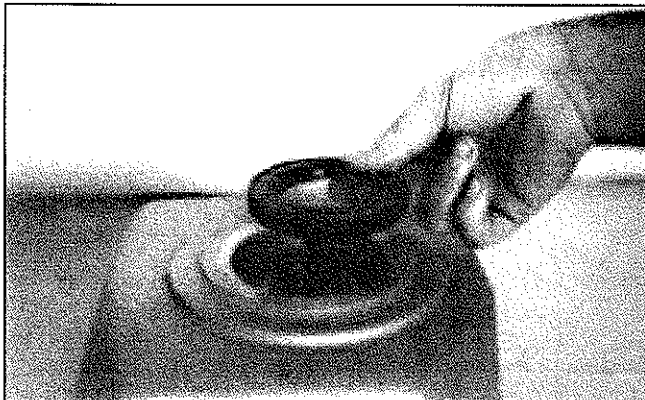

- 2.2 Insert the baffle (29) as shown in the picture. The fold of the baffle must correspond with the groove on the housing opposite to the breather position on the second fold into the same slot. The baffle must be straight and tight up against the under side of the housing.

NOTE: ZF 45C vers. TOYOTA 11 only

Install additional baffles (30, 31) and pin spacer (32).

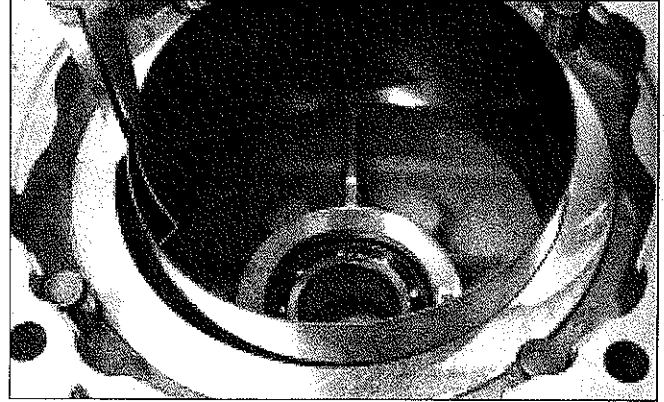

- 2.3 With special tool P.N. 500496 install needle bearing (41) into the cover (35).

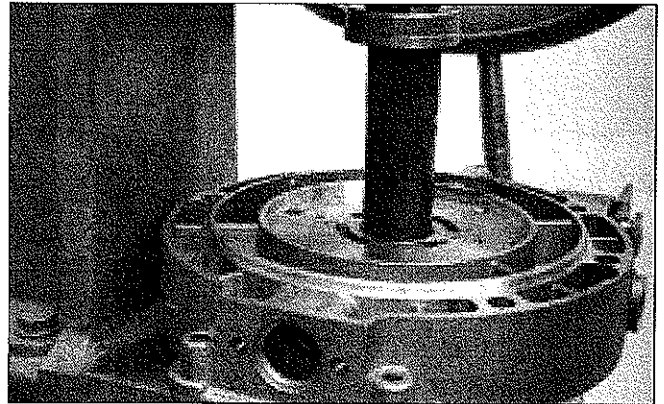

- 2.4 Install O-Rings (33) into the cover (35).

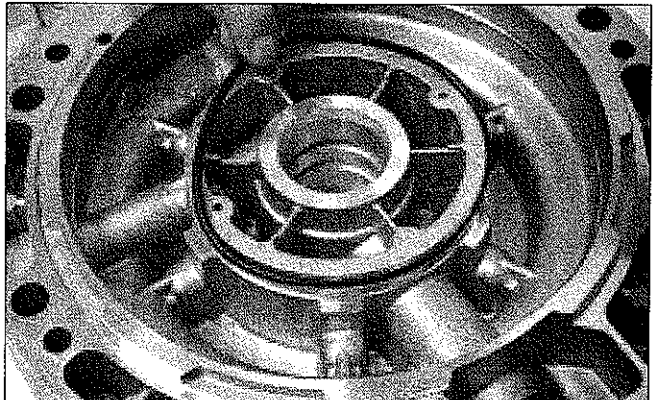

- 2.5 Install O-Ring (57) into the piston (56).
Wet O-Ring with ATF oil and using a plastic hammer, install the assembled piston (56) into cover (35).

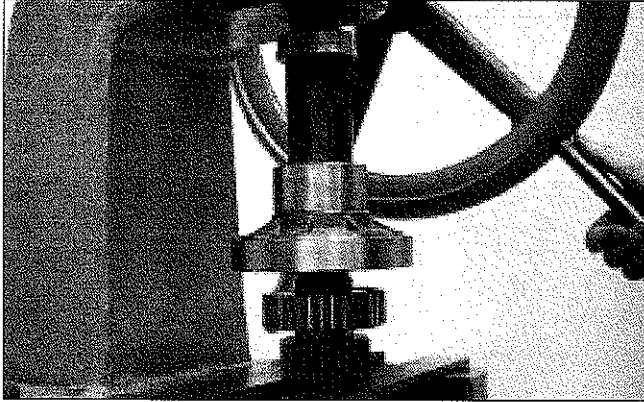

- 2.8 Assemble the cover (5).
Tighten bolts (6) with washer (10). Tightening torque: 18 Nm (13.3 lb ft.).

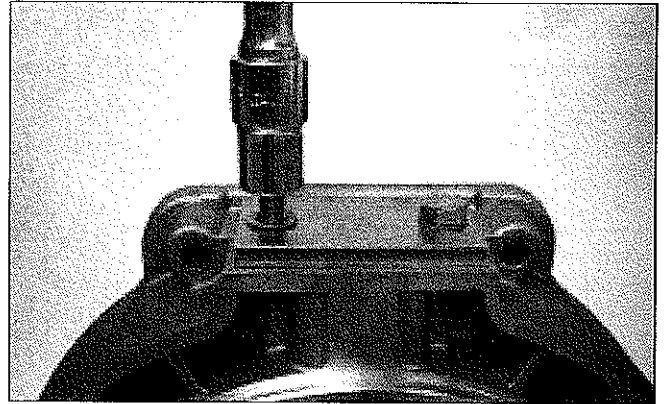

- 2.6 Install the filter (3).

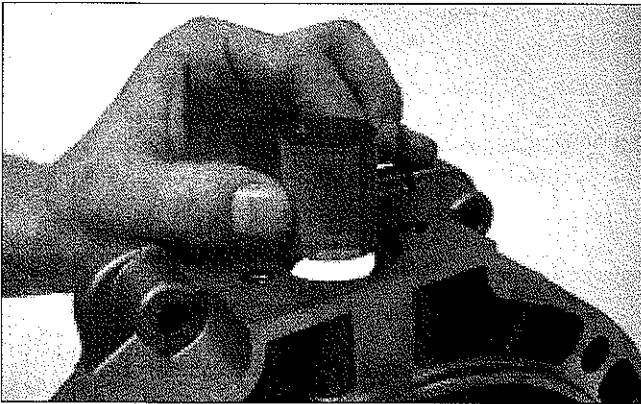

- 2.9 Install spool valve (24) onto front cover (35) checking for the correct alignment of groove.

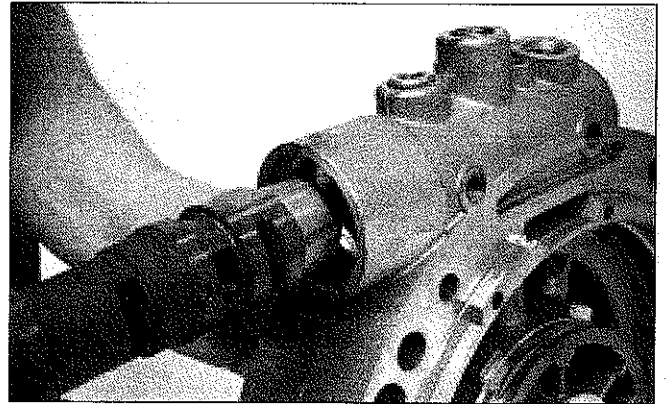

- 2.7 Install the rubber oil plate (4).

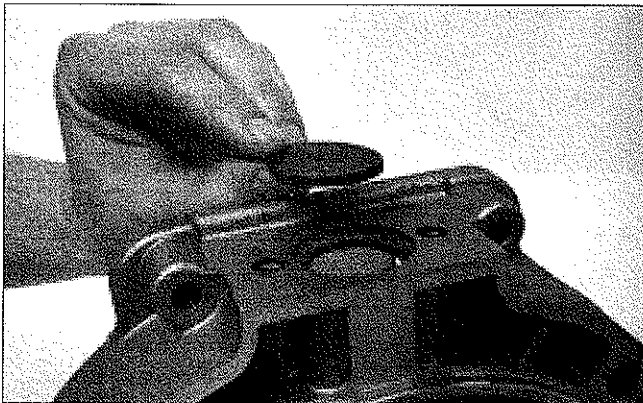

- 2.10 Install stop screw (17) with washer (13) Tightening torque: 12 Nm (8.9 lb ft.).
Install onto cover (35) ball (21), spring (20) and guide spring (18) together with sealing washer (13).
Guide spring (18) tightening torque: 12 Nm (8.9 lb ft.).
Turn slowly spool valve (24) to centre groove to ball (21).

NOTE: The plug shown in the figure with the arrow, will only be tighten if the distributor is correctly oriented.

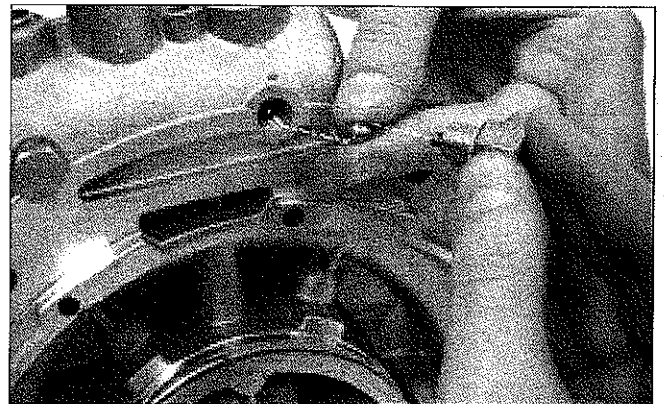

2.11 Install bushing (16) in the way that its bigger diameter is up.

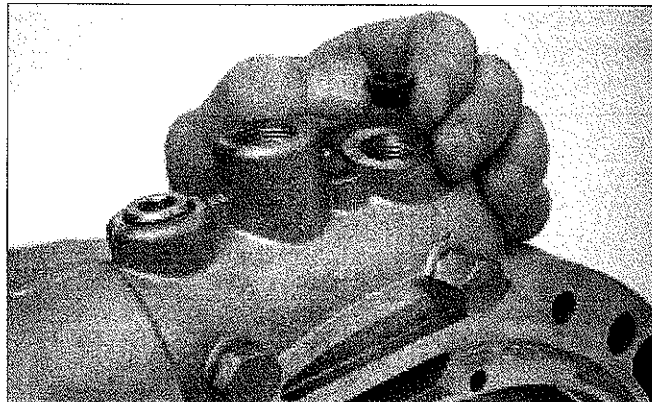

2.12 Install the ball (21).

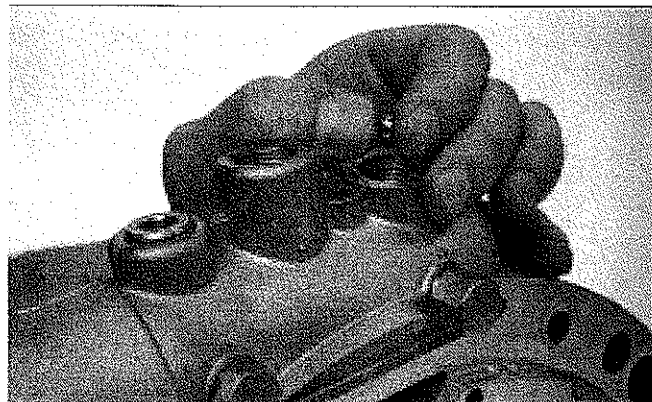

2.13 Install the microswitch (15).

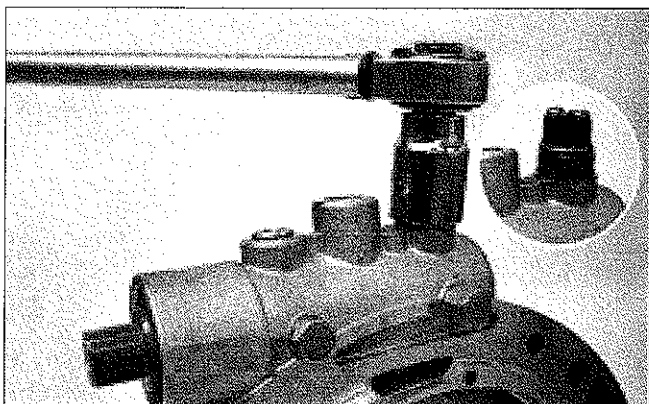

2.14 Install plug (14) and washer (19).

NOTE: Tighten to 25 Nm (18.5 lb ft.) torque.

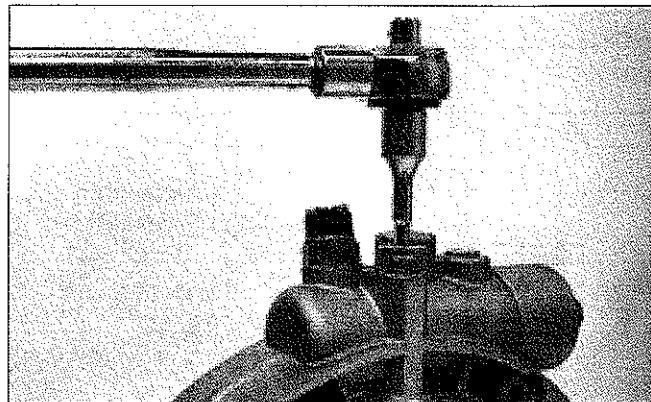

2.15 Install sealing ring (23) using the special tool P.N. 500495 and a plastic hammer.

NOTE: Check the correct position of sealing ring (23).

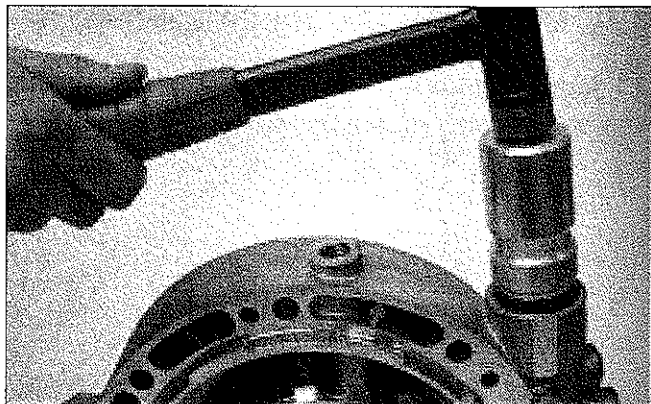

2.16 Install the lever (25) with bolt (11) washer (10) and nut (9).

NOTE: Tighten bolt (11) to 22.5 Nm. (16.5 lb ft.) torque.

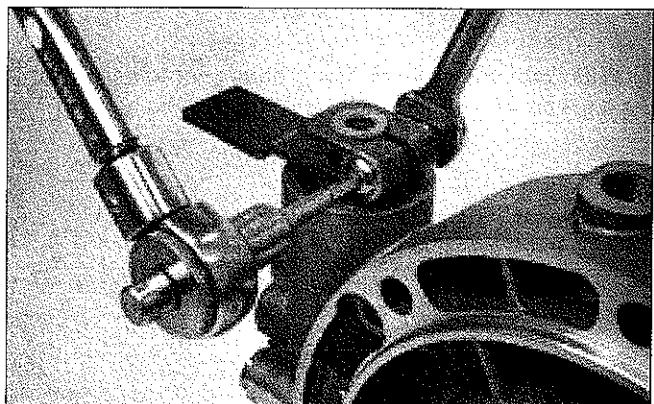

Neutral Safety Switch Function check

Connect neutral safety switch with a lamp in series to a battery. The neutral safety switch operates when the lamp is lighted.

NOTE: The lamp must be extinguished when the pin is pushed in.

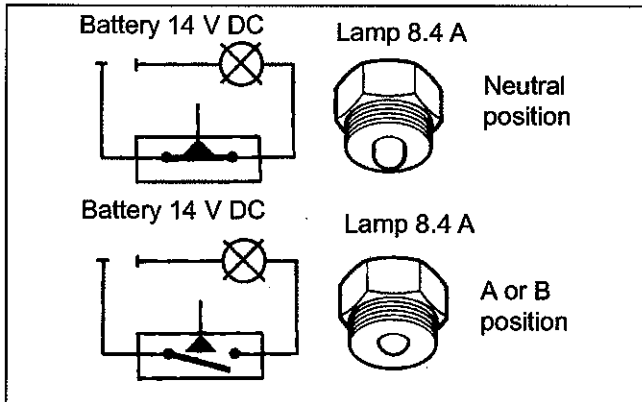

3.3 Install the thrust washer (45).



Be sure the bend correspond with the hole.

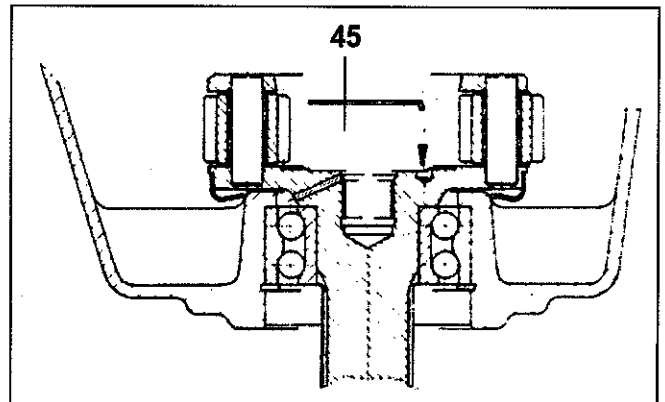

3. COMPLEMENTARY OPERATIONS

3.1 Install the friction bearing (46) with tool P.N. 500494.

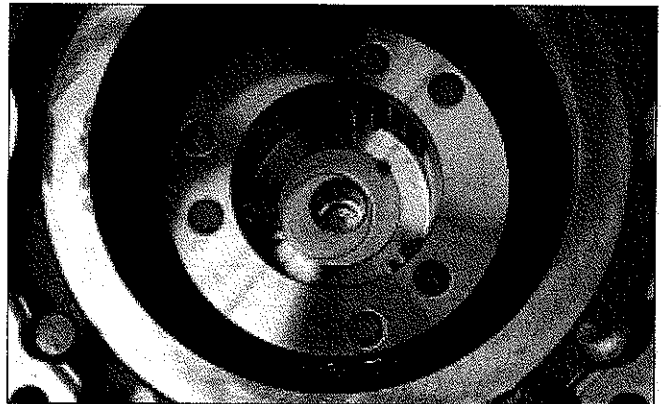
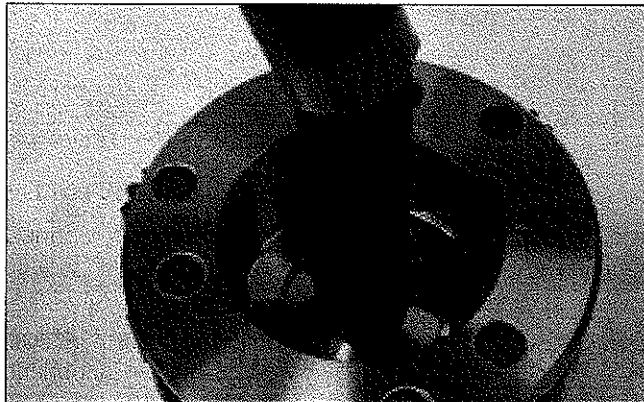

3.4 Assemble the input shaft assembly into the housing.

NOTE: To set correct play see item 3 page 23.

3.2 Assemble the output shaft by pressing the shaft into the housing.

NOTE: Coat output shaft with grease prior to assembly. As a precaution support the inner race of the bearing.

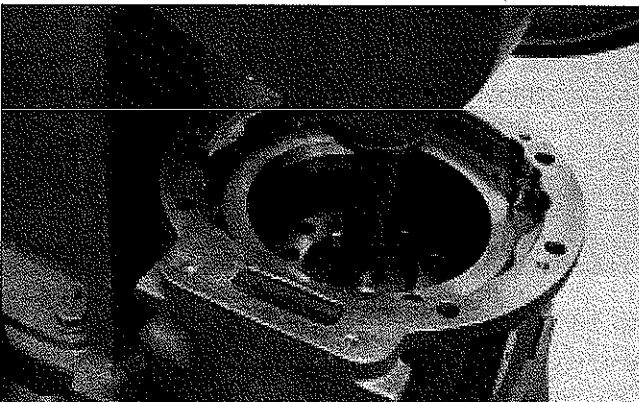

- 3.5 Install reverse clutch pack.
 Insert shims (64, 65).
 Install the first outer disc (63).

NOTE: To set correct play see item 3 pag. 24.

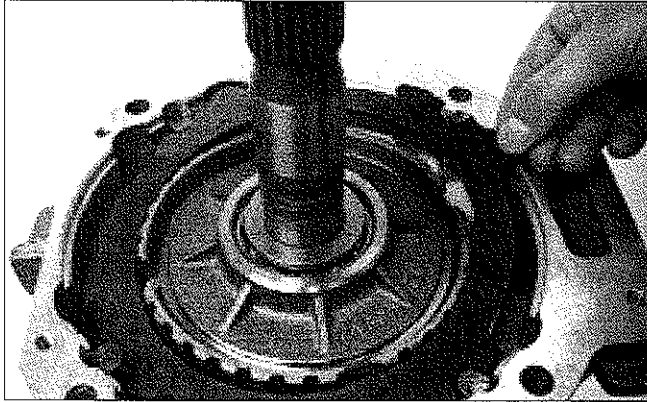

- 3.6 Install inner disc (62), outer disc (63) and inner disc (62).

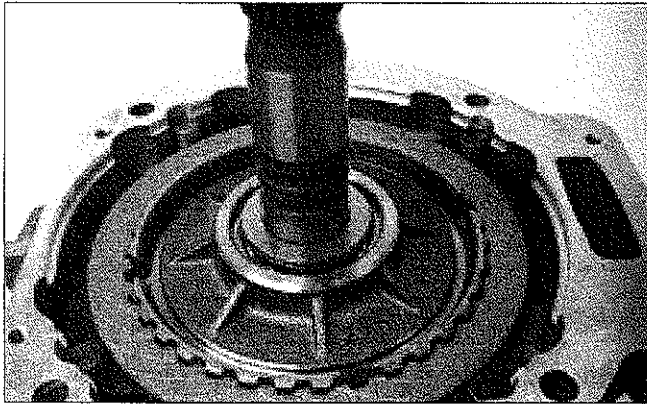

- 3.7 Spread front housing (36) with LOCTITE 574.

NOTE: Check that Loctite sealant covers the mating surface around the holes.

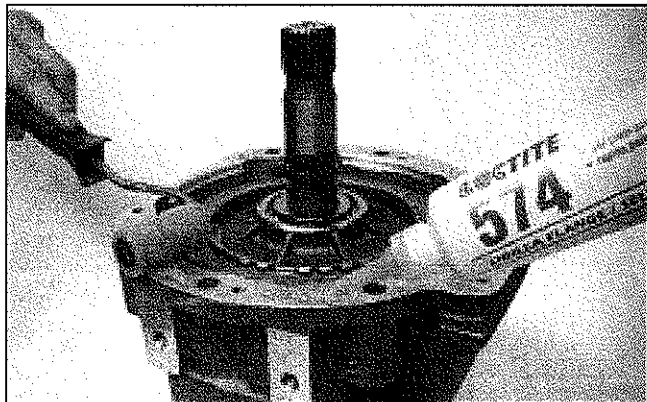

- 3.8 Install springs (58).

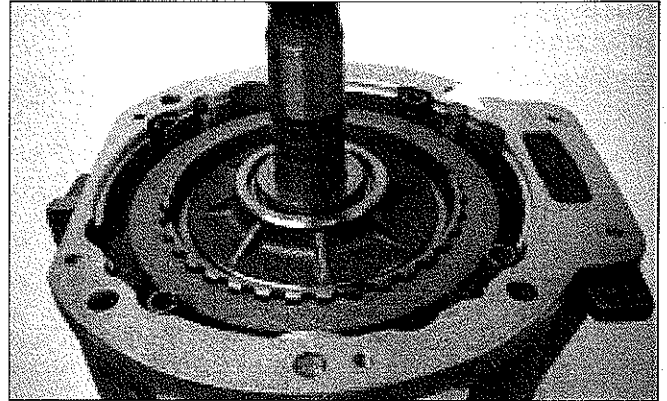

- 3.9 Install the final outer disc (63).

CAUTION

The last external disc (63) must cover the springs (see picture).

The first installed two outer discs (63) must have the four grooves in connection with the four housing springs. The last installed disc (63) must have the four grooves in connection with the four housing studs. The last outer disc is consequently installed upside-down compared to the first ones.

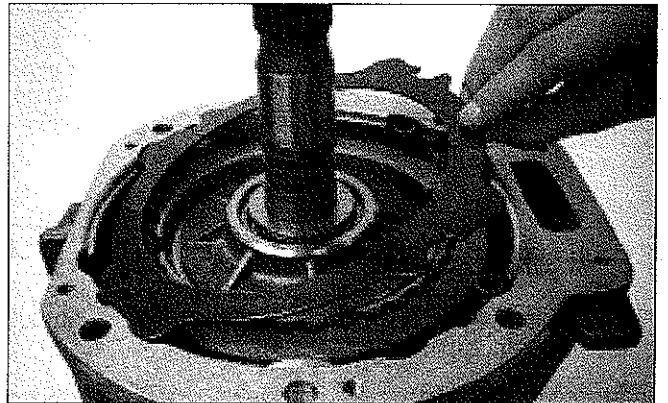

- 3.10 Coat sealing ring (39) with grease (for ex. POLYLUB GA 352 P).

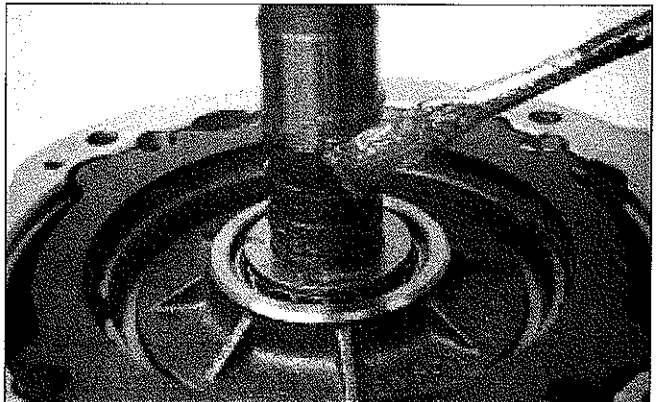

3.11 Assemble the cover down over the input shaft.

NOTE: Be sure of the correct position of the outer disc (63) when pressing the cover against the housing.

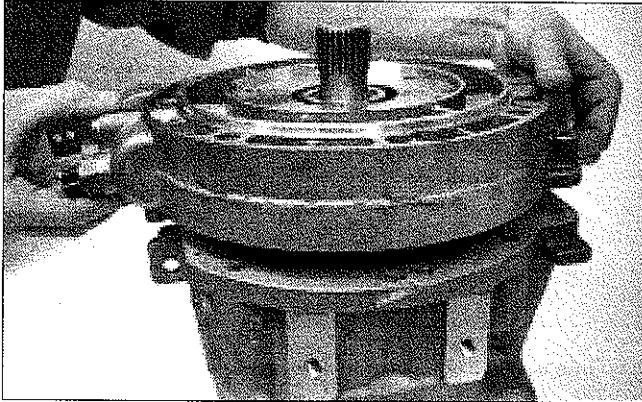

3.12 Install screws (7, 8) with washers (10).

NOTE: Tighten them to 18Nm (13.3 lb ft.) torque. Tighten the screws evenly to avoid binding the housing on the shaft.

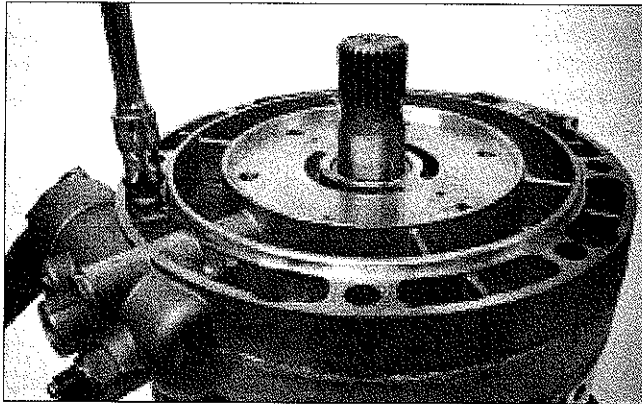

3.13 Install the output flange (66).

NOTE: Use LOCTITE 245 on the spline between output shaft and output flange.

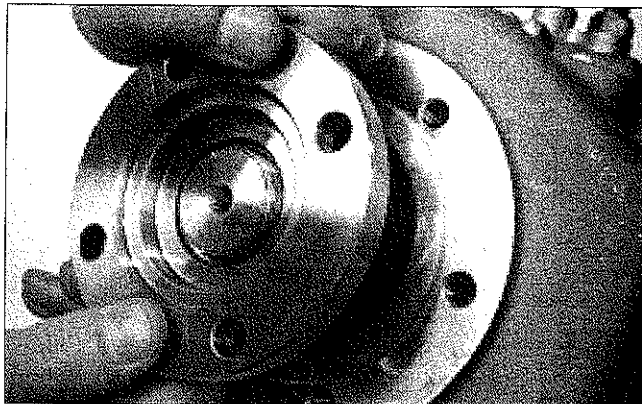

3.14 Wet O-ring (71) with grease.

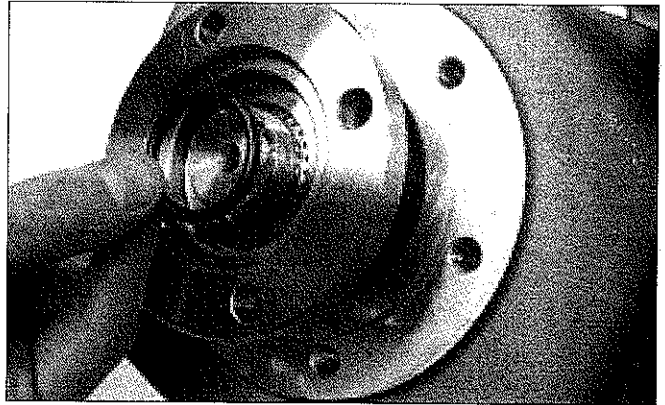

3.15 Tighten the output shaft ring nut (72). Use tool P.N. 500446 and P.N. 500502.

NOTE: Tighten the ring nut (72) to 120Nm (88 lb ft.) torque.

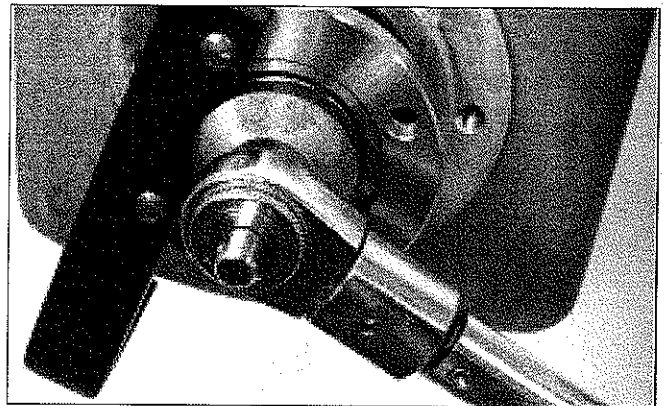

3.16 Install the breather (22) using LOCTITE 574 and the oil dipstick (26) together with O- Ring (27).

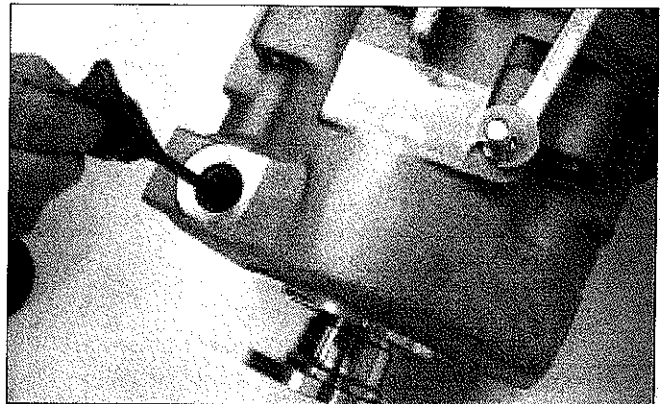

4. OIL PUMP

4.1 Install onto shaft (37) key (28) driving inner pump gear.

NOTE: Check carefully correct position of key (28).

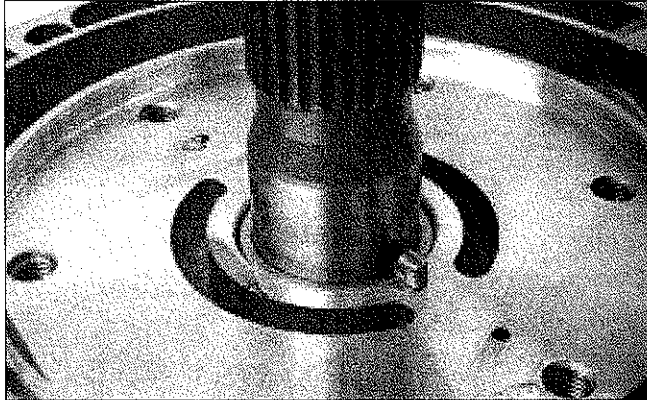

4.2 Install onto input shaft (37) the inner pump gear.

NOTE: Pump gear must be positioned in the way that the rounded groove aligned with the driving key (28).

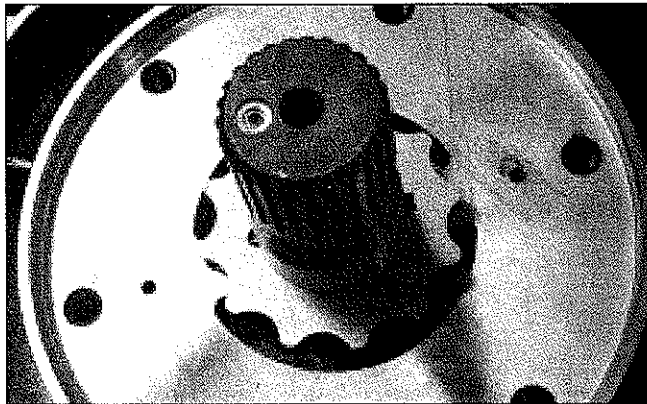

4.3 Spread out external diameter of sealing ring (1) with LOCTITE 574 and lips with grease (for ex. Klüber STABURAGS NBU 30).
With tool P.N. 500493 and suitable support press input shaft seal (1) into the oil pump cover (34).

NOTE: Check for correct position of sealing ring (1).

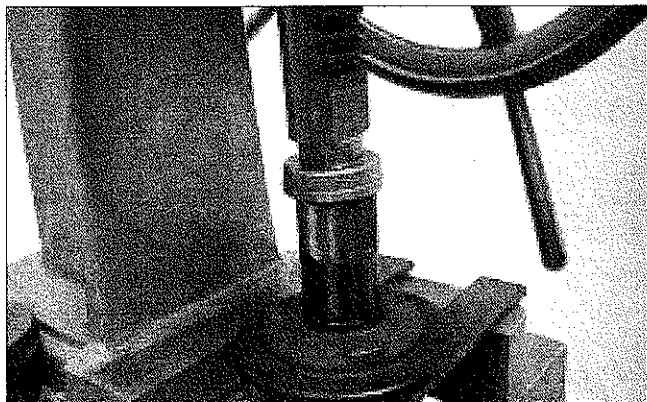

4.4 Wet O-Ring (33) with ATF fluid and install it into the pump cover.

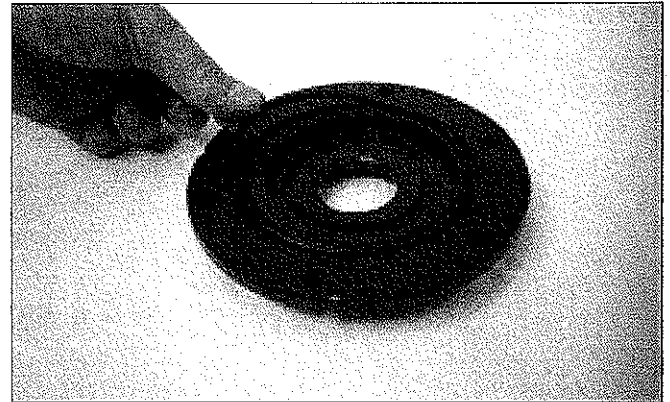

4.5 Install the external gear into the oil pump cover.

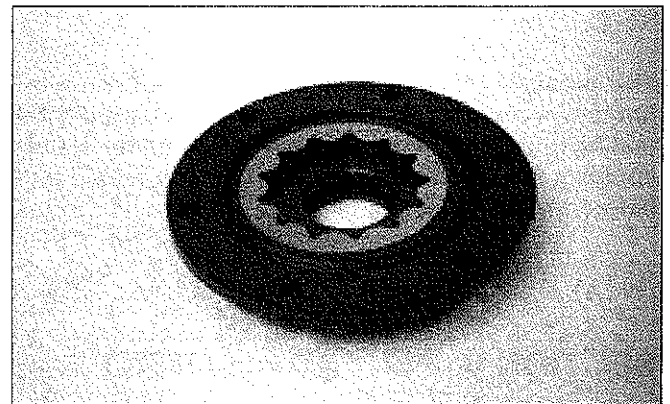

4.6 Install pump cover assembly.

NOTE: Be sure to properly index the arrow to point in the same direction as the engine rotates.

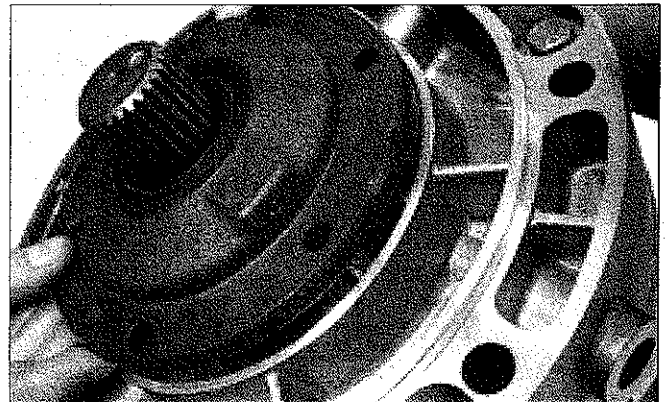

4.7 Install cover.

NOTE: Tighten the screws to 18 Nm. (13.3 lb ft.) torque in a criss cross pattern.

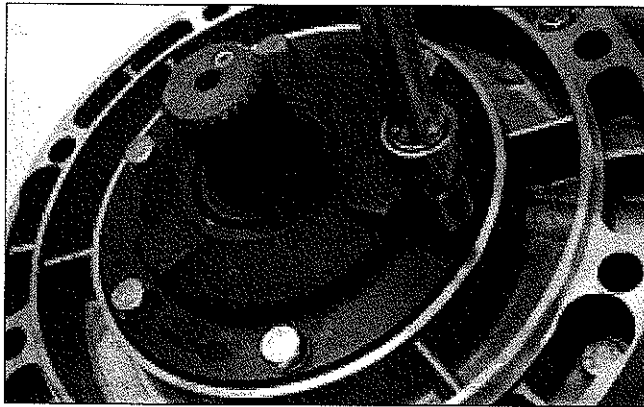

WARNING

The necessary time for a complete polymerization is 5 hours: we recommend therefore to clean carefully the mating surfaces with Loctite 7063. Cleaner before applying the Loctite 518 and wait the requested time before the spin test.

SECTION V: PLAY ADJUSTMENT

1. REVERSE CLUTCH CLEARANCE

NOTE: ONLY FOR MEASUREMENT THE LAST DISC (63) HAS TO BE INSTALLED IN THE SAME WAY AS THE OTHER ONES [NOT AGAINST THE SPRINGS (58)]

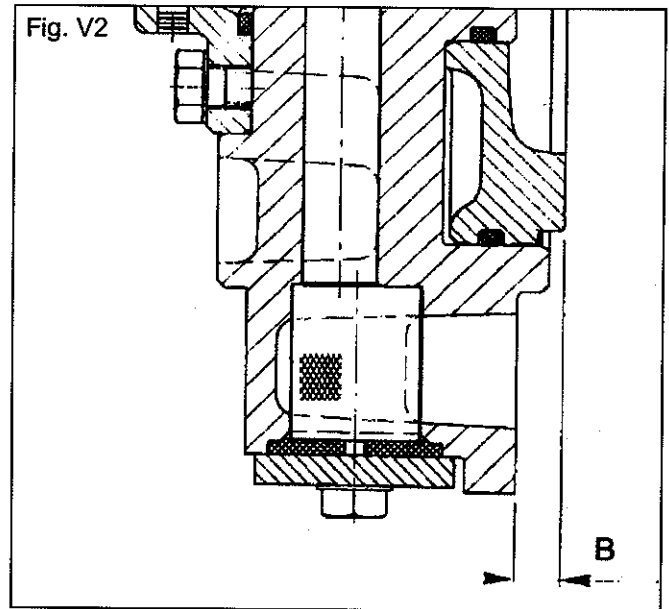
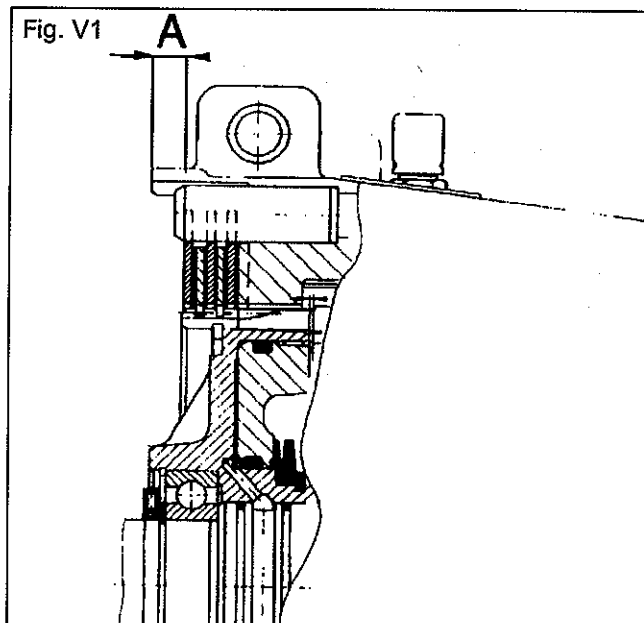

- 1) Install reverse clutch pack into housing:
3x external clutch discs p/n 3311 301 006 plus 2x internal clutch discs p/n 3311 302 027.
- 2) Take measurement "A" (See fig. no. V1).

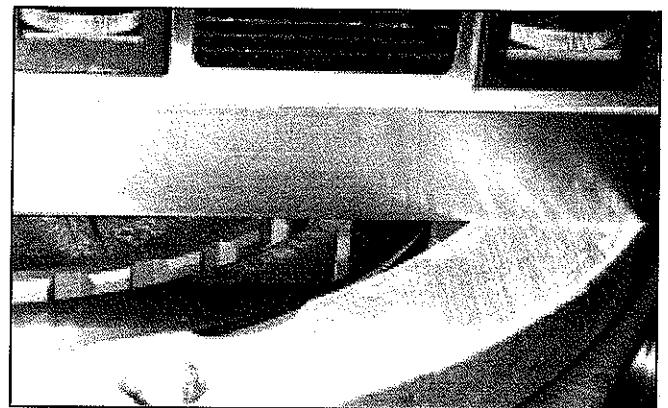

For example: "A" = 10.10 mm

3) Take measurement "B" (See fig. no. V2).

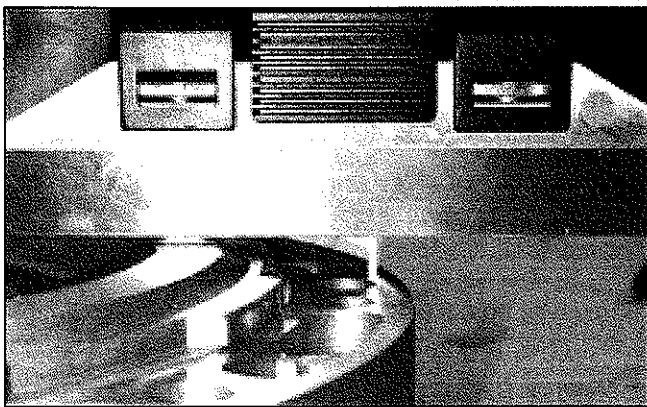
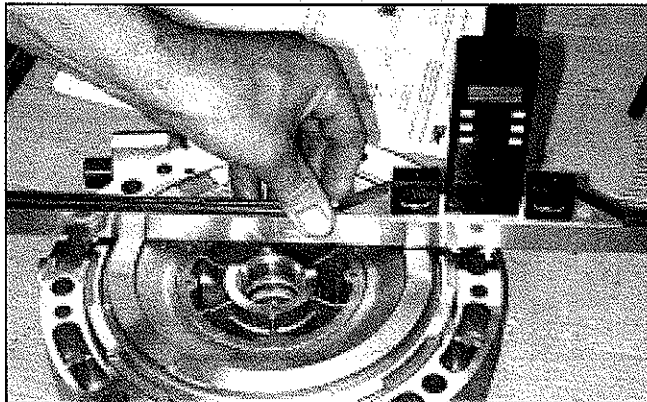

For example: "B" = 9.66 mm.

4) Select proper tickness shims to set the gap "R".

Shims available:

Shim 0.3 mm p/n 3311 301 042

Shim 0.5 mm p/n 3311 301 043

$$"R" = "A" - "B"$$

For example: "R" = 0.44 mm

"R" must be from 0,016" to 0,020" (0.40 mm to 0.50 mm)

2. FORWARD CLUTCH CLEARANCE

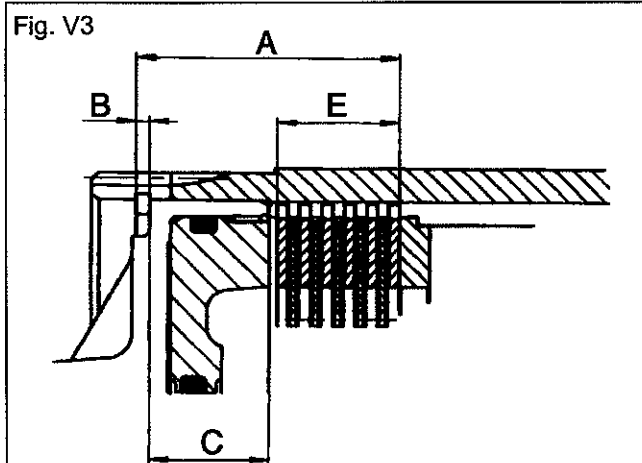

1) Install end disc p/n 3311 302 034 in ring gear p/n 3311 302 026.

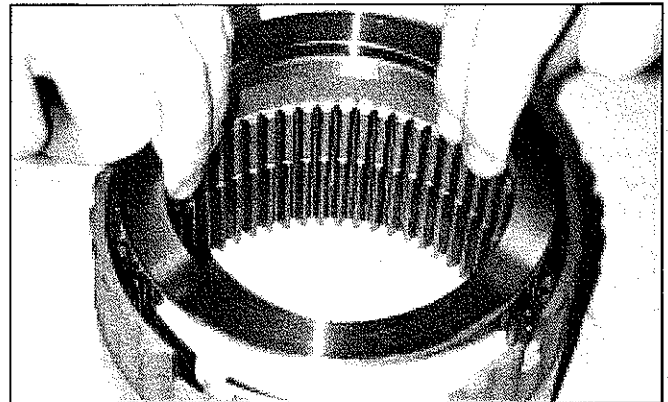

2) Install snap ring p/n 0630 513 066 in ring gear.

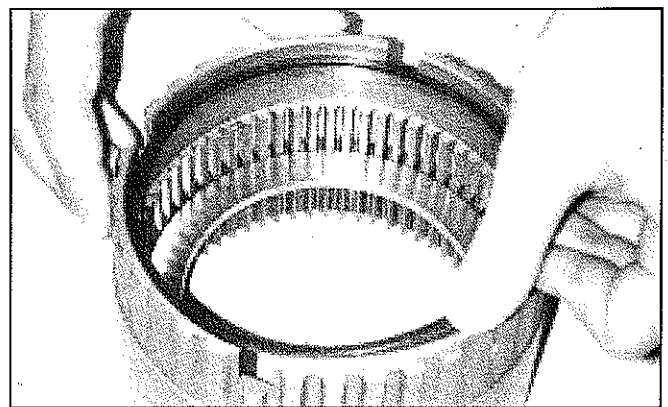

3) Set 0.00 mm of the caliper on the snap ring.

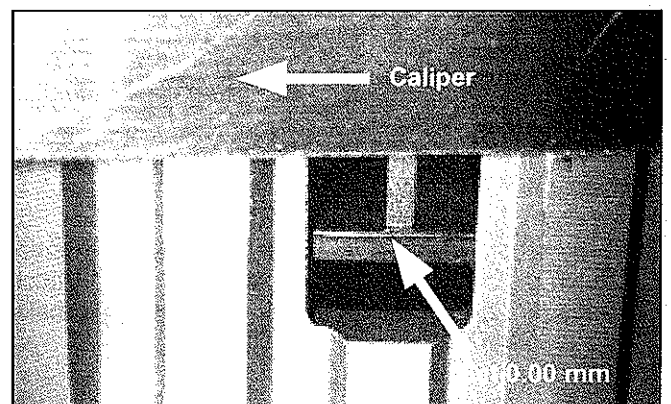
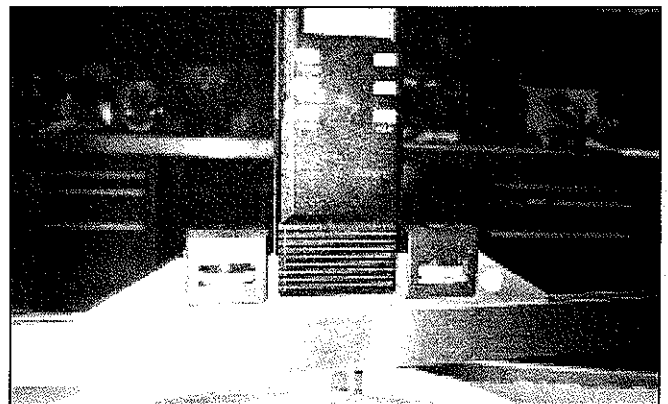

- 4) Take measurement "A" in different points and make the average.

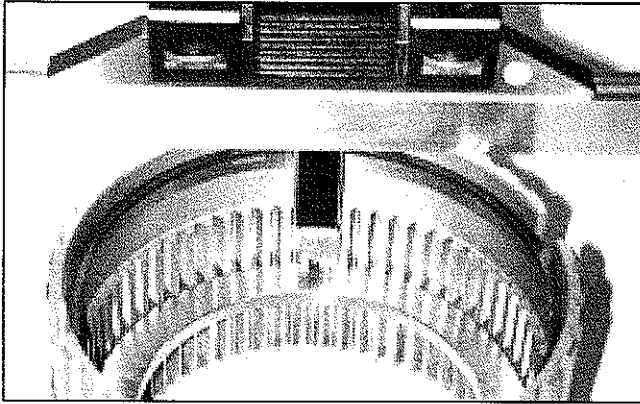

For example: "A" = 48.53 mm

- 5) Remove snap ring p/n 0630 513 066 and measure its thickness "B".

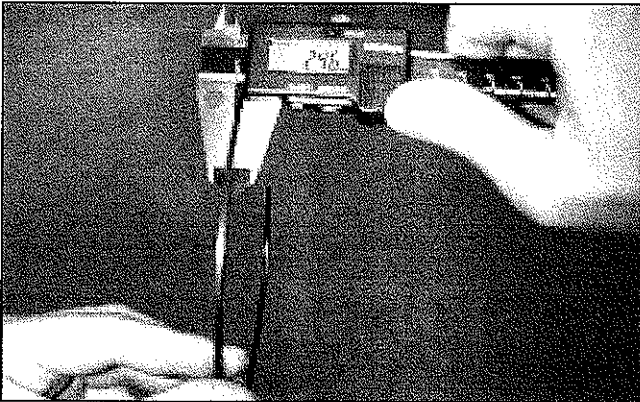

For example: "B" = 2.46 mm

- 6) Take measurement "C" on forward clutch housing assembly in different points and make the average.

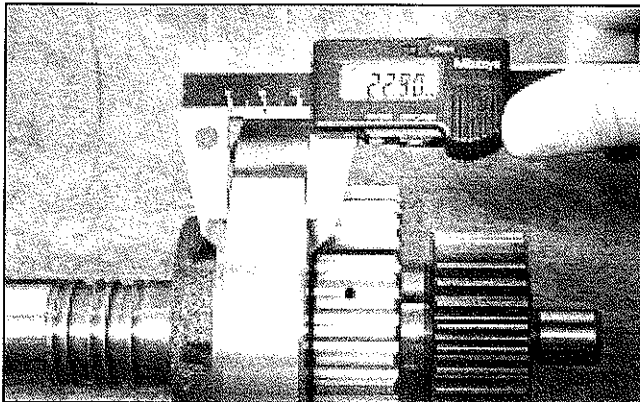

For example: "C" = 22.90 mm

- 7) Take measurement "E" of the clutch pack (6x external clutch discs p/n 3311 302 029 plus 5x internal clutch discs p/n 3311 302 028) in different points and make the average.

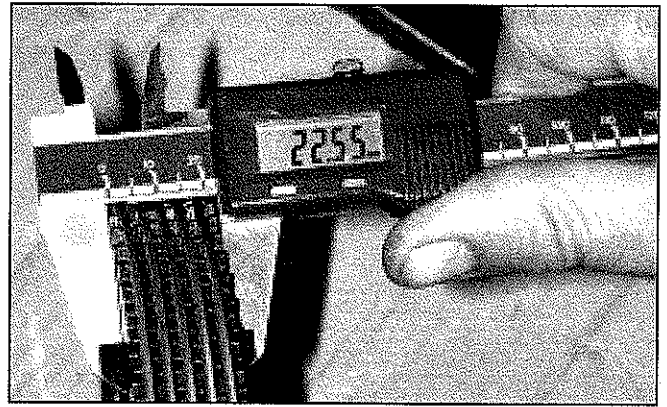

For example: "E" = 22.55 mm

- 8) Select proper thickness shims to set the gap "F".

Shims available:

Shim 0.2 mm p/n 0630 004 229

Shim 0.3 mm p/n 0630 004 124

$$"F" = "A" - "B" - "C" - "E"$$

For example: "F" = 0.62 mm

"F" must be from 0,018" to 0,022" (0.45 mm to 0.55 mm)

3. INPUT SHAFT PLAY

Install input shaft assembly in housing assembly. Install shims (75) (76), spacer (42b) needle bearing (42a) and other spacer.

Take measurement "L" between spacer (42b) and housing (36) mating surface.

Use a tool bar and a standard caliper.

(as shown in figure in figure V4).

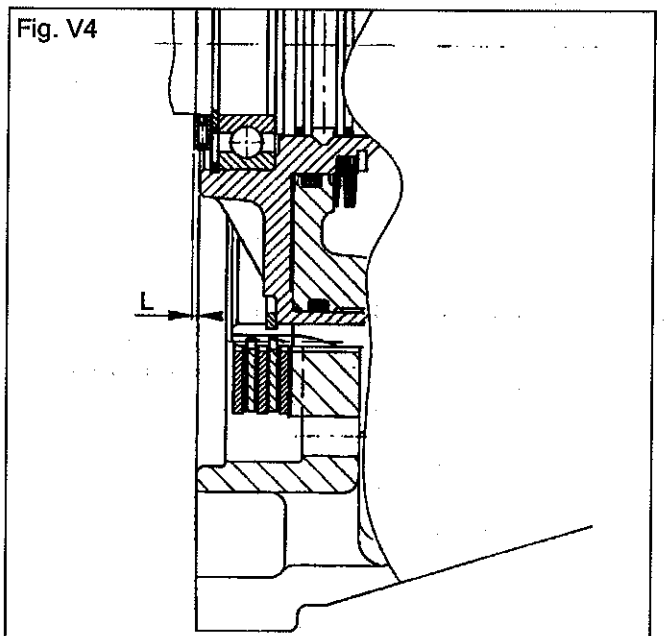

Take measurement "M" between cover (35) mating surface and the surface shown on figure V5.
 Select proper thickness shims (75) (76) to set the gap "I".

$$"I" = 0.008" \text{ to } 0.02" \\ (0.2 \text{ mm to } 0.5 \text{ mm})$$

$$"I" = "M" - "L"$$

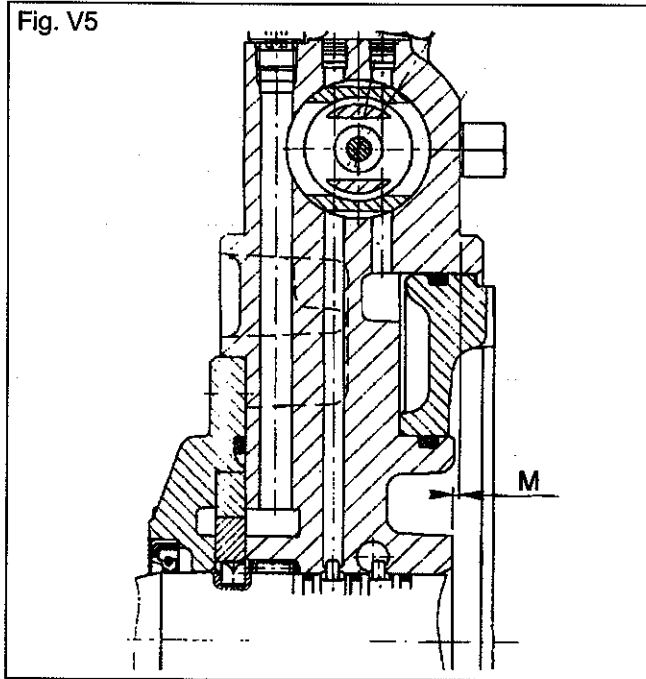

WARNING

To check the play, once the gearbox is assembled, use tool clamp ring P.N. 618582, as shown in figure V6.



CAUTION

Set down to the housing the input shaft and measure with a dial indicator the play "I" moving the input shaft with the aid of two pry bars.

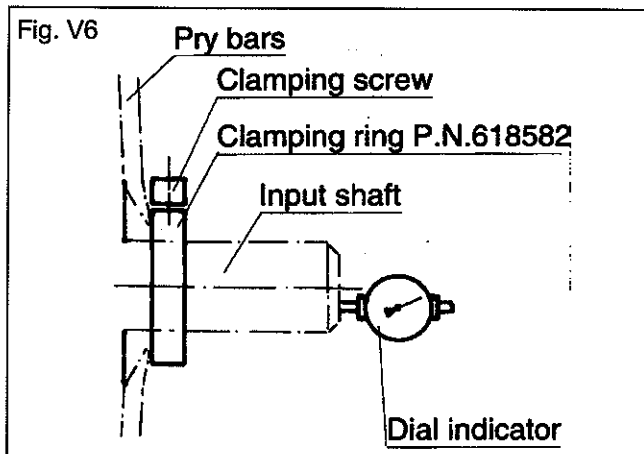

4. OUTPUT SHAFT BEARING PLAY

This measurement has to be taken only if housing (36) is replaced.

Install snap ring (70) in housing (36).

Take measurement "S" as shown in picture V7.

Remove snap ring (70) and measure its thickness "V".

Measure width "R" of the bearing.

Select proper thickness shims (68) (69) to set maximum play "Z"

$$"Z" = "S" - "V" - "Q"$$

$$"Z" = 0,004" (0.1 \text{ mm})$$

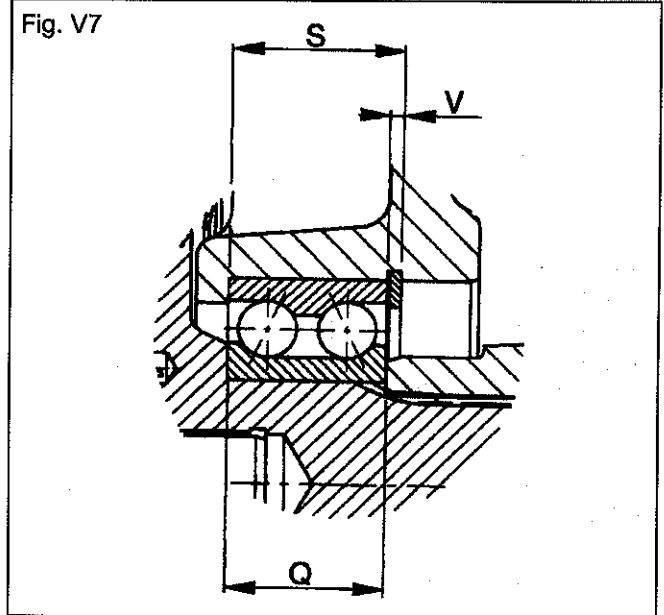

SECTION VI: TIGHTENING TORQUES

Part	Size	Torque in Nm	Torque in lb ft.
Housing bolts	M8	18 Nm	13 lb ft.
Oil pump bolts	M8	18 Nm	13 lb ft.
Plate oil filter	M8	18 Nm	13 lb ft.
Distributor lever	M8	23 Nm	17 lb ft.
Output flange ring nut	M32x1.5	120 Nm	88 lb ft.
Breather filter (with Loctite n° 574)	-	Hand tight	Hand tight
Dipstick	-	Hand tight	Hand tight
Stop screw	-	12 Nm	8.9 lb ft.
Guide bolt	-	12 Nm	8.9 lb ft.
Plug 3/8 - 18 NPTF	-	10 Nm	7.4 lb ft.
Pressure plug	-	25 Nm	18.5 lb ft.

SECTION VII: FUNCTION TEST

1. FILLING UP WITH TRANSMISSION FLUID

Filling with ATF fluid into the dipstick opening.

Quantity:

ZF 45C vers. 10,001: 2.1 US-qts (2,0 liters)

ZF 45C Walter vers. 002: 2.1 US-qts (2,0 liters)

ZF 45C Toyota vers. 11,003: 1.7 US-qts (1,6 liters)

ZF 63C vers. 07,001: 2.1 US-qts (2,0 liters)

ZF 88C vers. 001: 2.1 US-qts (2,0 liters)

ATF (Automatic Transmission Fluid) such as, per list on section IX.

2. CHECK FLUID LEVEL

Carry out a trial run after oil filling.

Set shifting lever to neutral position (N). Start engine and let it run idle for a short time to fill the cooler and pipelines with transmission oil. Stop the engine and check oil level again.

If necessary, top up with oil. Excessive oil should be removed. The fluid level on the dipstick (item 1, figure B) should be between the min. end max marks. The fluid level should be checked again after a short driving period.

NOTE: Some transmissions may have different oil dipsticks, depending on the version:

A) When inserted into the housing hole, it expands by turning the handle in clockwise direction; (see Fig item A).

B) It is threaded (See Fig. item B).

IMPORTANT

Oil check with threaded dipstick (B) must be done in a different way compared with the one not threaded (A).

A) Oil dipstick and housing hole not threaded: dipstick completely inserted into hole.

B) Oil dipstick and housing hole threaded: dipstick not inserted into the housing hole (not screw in).

NOTE: Dipstick version A doesn't require any O-Ring, dipstick version B requires O-Ring. (see item 27 in explosion drawing pag. 41.

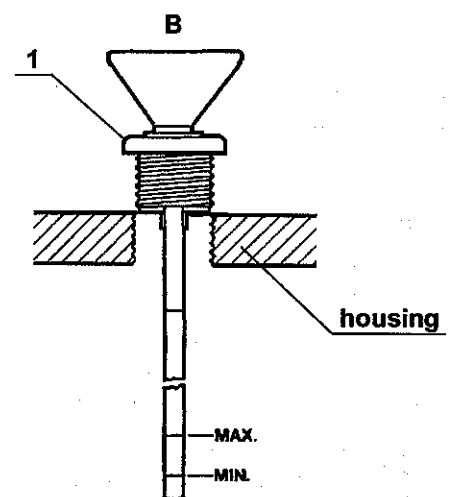
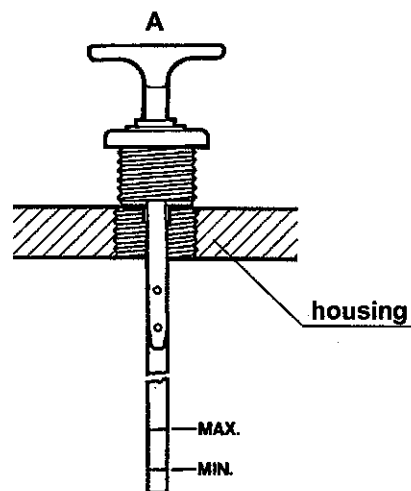



3. FUNCTION TEST

When the transmission has been completely assembled and filled up with transmission fluid, it would be convenient to make a function test.

This test can be carried out on a bench test rig, or in a boat. If no fluid cooler can be connected, a hydraulic hose must be connected between the inlet and outlet of the hydraulic pump.

Measuring instruments required

- Pressure gauge 0-25 bar (0-360 psi), with connecting thread M10x1 (oil pressure gauge set with hole and adaptor is available).

- Temperature gauge 0-120°C (0-250°F), connecting thread 3/8"-18NPSF.
- Flow meter 0-35 liters/min (0-10 gals/min).

Tests to be carried out:

- 1 Fluid leaks
- 2 Noise
- 3 Direction of rotation, LH/RH
- 4 Lube oil temperature
- 5 Shifting pressure
- 6 Lube oil flow rate

THE FUNCTION TEST SHOULD BE CARRIED OUT FOLLOWS:

Motor speed rpm	Shift lever position	Durat. minutes	Test
800-1000	neutral	5	1, 2
600-800 (idling speed)	A<->B position repeatedly	-	1, 2, 3
1500-2500	B position	*	1, 2, 4
600-800 (idling speed)	A<->B position repeatedly	-	1, 2, 3
idling- max. speed	A position	-	1, 2, 5**, 6**
600-800 (idling speed)	A->B position	-	1, 2
idling- max. speed	B position	-	1, 2, 5**, 6**

* Until a fluid temperature of 75-80°C (167-176° F) has been reached.

** At different speeds.

A = FORWARD

B = REVERSE

4. SHIFTING PRESSURE ZF 45C / 63C / 88C

ZF 45C

Max 20 bar (290 p.s.i.) at 70 °C (160 F°) and 4000 rpm.

Min 14 bar (203 p.s.i.).

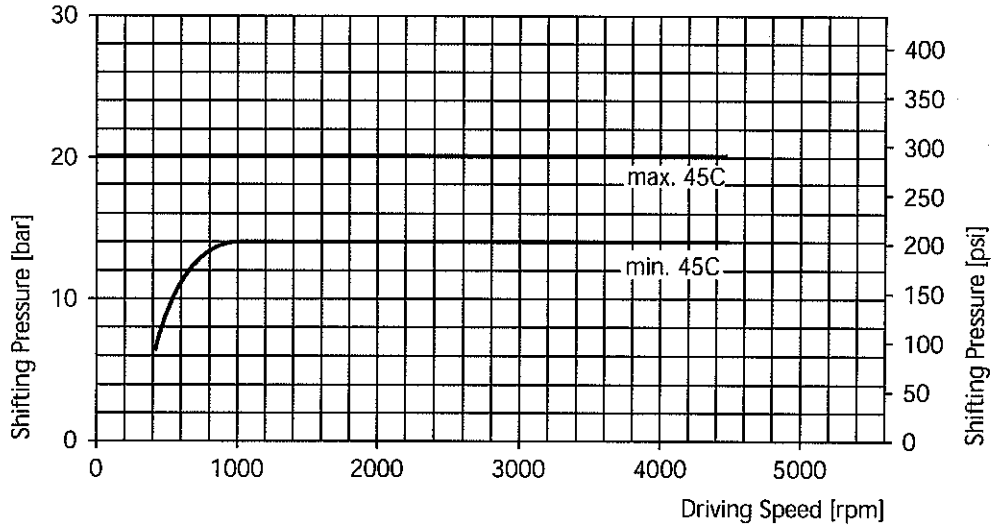

ZF 63C

Max 23 bar (333.5 p.s.i.) at 70 °C (160 F°) and 4000 rpm.

Min 17 bar (246.5 p.s.i.).

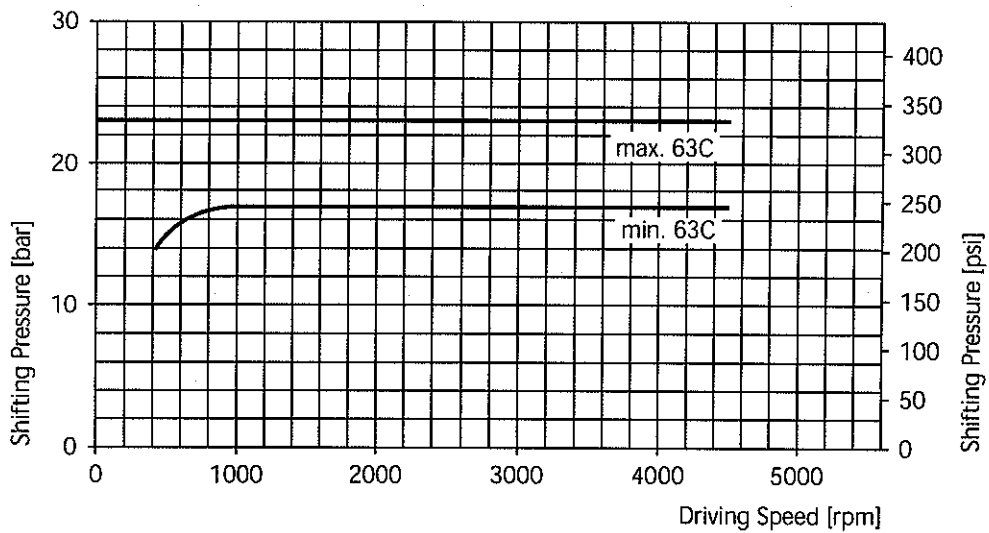

ZF 88C

Max 24 bar (348 p.s.i.) at 70 °C (160 F°) and 4000 rpm.

Min 19 bar (275.5 p.s.i.).

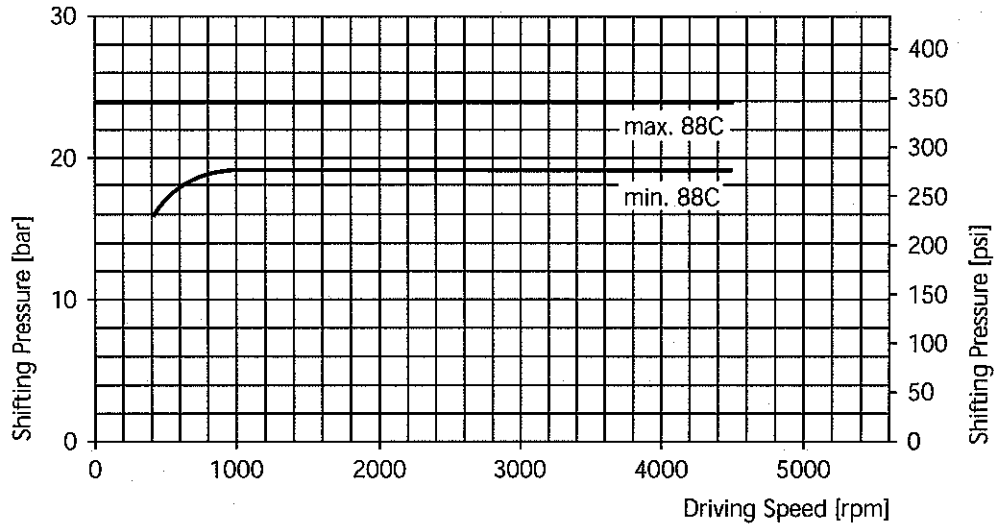

5. LUBE OIL DELIVERY ZF 45C / 63C / 88C

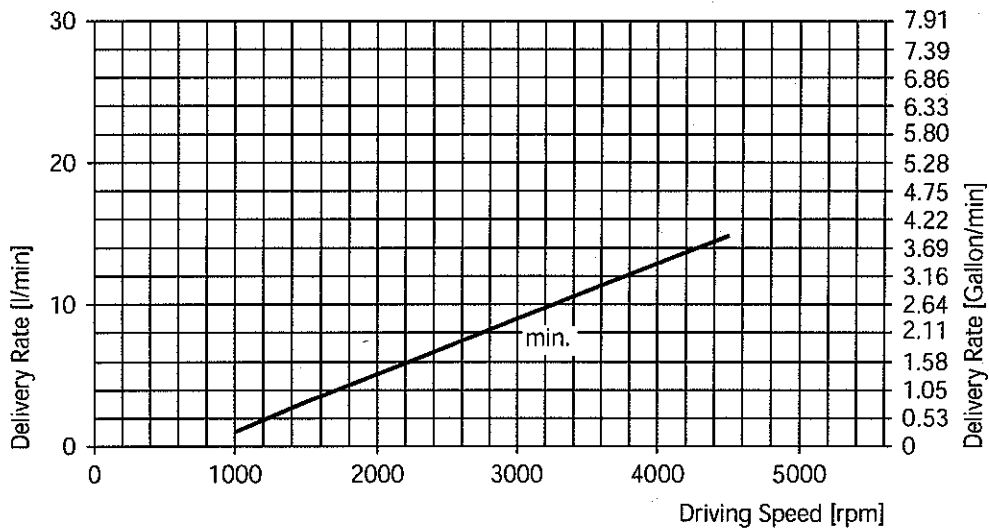

SECTION VIII: TROUBLESHOOTING

In case of trouble, check first whether all items of the present mounting and operating instructions have been completed with.

The subsequent tables will assist you in troubleshooting and finding a remedy yourself.

If any interventions are necessary on the transmission, please refer to the Repair Manual.

Warranty claims will be forfeited if work on the transmission is performed by un-authorized persons during the warranty period.

Syptom	Possibly cause	Remedy
1. Transmission	1.1 Shifting lever is loose cannot be shifted 1.2 Remote control does not permit lever travel required for testing 1.3 Remote control faulty 1.4 No shifting pressure available	Tighten clamping bolt on shifting lever Lift remote control off, if gears can be shifted by hand, correct remote control. Repair remote control Refer to 7
2. Delayed shift time	2.1 Shift linkage misadjusted; not allowing full engagement 2.2 Wrong clutch play adjustment	Lift remote control off, if gear can be shifted by hand, correct remote control. If the transmission cannot be shifted correctly-by hand, replace the control valve. Disassemble the gearbox and check forward or reverse clutch clearance.
3. Clutch is slipping, i.e. propeller speed too low as compared to engine speed	3.1 Inadmissible fluid used 3.2 Fluid contains water 3.3 Shifting pressure too low 3.4 Wear on clutch discs 3.5 Piston rings in clutch are damaged	Drain fluid, refill with prescribed fluid, flush transmission while engine runs in neutral position, drain fluid, refill transmission. Refer to 9 Refer to 6 Disassemble transmission, replace clutch discs Disassemble transmission, replace piston rings
4. Transmission locked	4.1 Medium piston ring in input shaft in control block is faulty. 4.2 Warped discs due to overheating of slipping clutch 4.3 Needle bearings on input shaft are worn out 4.4 Pump gear is worn	Replace piston ring. Refer to 3 Disassembly transmission and repair. Disassemble transmission and repair
5. Output shaft turns in neutral position	5.1 Rotary slide valve in control valve is worn 5.2 Faulty needle bearing on input shaft 5.3 Warped discs due to overheating of slipping clutch	Replace control valve Disassembly transmission and input shaft, replace bearing concerned and other damaged parts Refer to 3

Syptom	Possibly cause	Remedy
6. Shifting pressure too low	6.1 Fluid filter clogged	Clean or replace fine filter Top-up with fluid; in case of fluid loss check transmission, cooler and pipelines for leakage and remedy same; also refer to 10. through 13.
	6.2 Fluid level in transmission too low.	
	6.3 Fluid pump is worn out	
	6.4 Spring in shifting pressure relief valve is broken	Replace cover containing fluid pump Replace control valve
	6.5 Piston rings on input shaft are faulty	
	6.6 O-rings in clutch are faulty	
7. No shifting pressure available	7.1 Direction of engine rotation does not agree with arrow on transmission	Rotate pump assy. of 180 °
	7.2 No fluid in the transmission	Refill with fluid Clean or replace fine filter Top-up with fluid. In case of loss of fluid check transmission, cooler and pipelines for leakage and remedy same, also refer to 10. through 13. Replace pump cover and pump Remove control block. Replace fitting key, replace any other faulty parts
	7.3 Fine filter is dirty	
	7.4 Fluid level in transmission is too low	
	7.5 Fluid pump worn out	
	7.6 Fitting key in input shaft for fluid pump drive is broken	
8. Excessive fluid temperature	8.1 Fluid cooler is too small	
	8.2 Excessive fluid in transmission	
	8.3 Fluid cooler is dirty on water side	
	8.4 Worn fluid pump in transmission	
	8.5 Faulty piston rings in input shaft	
	8.6 Clutch is slipping	
	8.7 Clutch does not open completely due to worn disc support	
	8.8 With fluid cooler in bypass and unfavorable arrangement of pipelines too little coolant waterflows through bypass to cooler	
9. Water in the fluid, fluid looks milky	9.1 Fluid cooler faulty	Repair leakage at cooler or replace cooler. Change transmission fluid Remedy cause for water level in engine compartment change transmission fluid.
	9.2 High water level in engine compartment, water entering through output shaft seal or breather.	
10. Fluid leakage at output shaft	10.1 Breather clogged with paint or dirt	Remove paint or dirt from breather Disassemble transmission, replace seal.
	10.2 Shaft seal faulty	

Symptom	Possibly cause	Remedy
11. Fluid leakage at breather	11.1 Excessive fluid in transmission	Pump excessive fluid out with commercial hand pump
12. Fluid leakage at joints	12.1 Bolts are not tight 12.2 Seals on bolts have used several times 12.3 Mating faces are contaminated, no surface seal applied	Tighten bolts with prescribe torque. Replace seals, tighten bolts with prescribed torque Unscrew housing half, finish mating faces with oilstone or finishing file, apply surface seal. Assemble transmission, tighten bolts with correct torque.
13. Transmission noise becomes louder	13.1 Fluid level too low so that pump sucks in air. 13.2 Damage starting on flexible coupling due to wear or fatigue, possible due to misalignment between engine and transmission. 13.3 Beginning damage of bearings in transmission, e.g. due to torsional vibrations, running without fluid, overload, wrong alignment of transmission excessive engine output 13.4 Beginning damage of gearings, e.g. due to torsional vibrations, running without fluid, overload 13.5 Dirty fine filter	Top up with fluid to marking on dipstick. Replace flexible coupling. Check alignment between engine and transmission. Disassemble transmission, replace bearings concerned and other faulty parts. Find causes and remedy. Disassemble transmission, remove faulty parts. Clean or replace fine filter
14. Chattering transmission noise mainly at low engine speed	14.1 The engine or propeller generate torsional vibrations in the drive unit which produce a "chattering" noise in the transmission 14.2 Misaligned propeller shaft on output	Mount a flexible coupling with another stiffness factor between engine and transmission; a coupling with a higher stiffness factor might be sufficient. Otherwise analyse the torsional vibrations to find out the required stiffness for the coupling. Mount and align propeller shaft strictly according to instructions issued by shaft manufacturer.

SECTION IX: AUTOMATIC TRANSMISSION FLUID

MANUFACTURER	PRODUCT	MANUFACTURER	PRODUCT
ADDINOL MINERALÖL GMBH, KRUMPA/D	• ADDINOL ATF D IID • ADDINOL ATF D III	ENGEN PETROLEUM, CAPE TOWN/ZA	• ENGEN ATF 22D
AGIP PETROLI SPA, ROM/I	• AGIP ATF II D • AGIP ATF D 309 • AGIP ATF PLUS • AGIP DEXRON III	ERTOIL SA, MADRID/E	• TRANSMISIONES AUTOMATICAS D2 • ESSO ATF D (21611) • ESSO ATF F-30320 • ESSO ATF D (21065)
AGIP SCHMIERTECHNIK, WÜRZBURG/D	• AUTOL GETRIEBEÖL ATF-D • AUTOL GETRIEBEÖL ATF III D	FIAT LUBRIFICANTI, VILLASTELLONE/I	• TUTELA GI/A
ARAL LUBRICANTS GMBH, BOCHUM/D	• ARAL GETRIEBEÖL ATF 22 • ARAL GETRIEBEÖL ATF 55 F-30589	FINA EUROPE SA, BRÜSSEL/B	• FINAMATIC II-D
AVIA MINERALÖL -AG, MÜNCHEN/D	• AVIA FLUID ATF 86	FUCHS LUBRICANTS (UK), DERBY/GB	• SILKTRAN MP-ATF • SILKTRAN PSV ATF
BLASER SWISSLUBE, HASLE-RÜEGSAU/CH	• BLASOL 229	FUCHS MINERALÖLWERKE, MANNHEIM/D	• TITAN ATF 4000
BP OIL DEUTSCHLAND, HAMBURG/D	• FRONTOL UNIVERSAL-ATF 100	GINOUVES GEORGES SA, LA FARLEDE/F	• YORK LT 785
BP OIL INTERNATIONAL, LONDON/GB	• AUTRAN DX II • AUTRAN MBX • AUTRAN DX III (F-30370) • AUTRAN DX III (F-30381)	GULF OIL (GB) LTD, CHELTENHAM/GB	• UNIFLUID • ATF 2
BUCHER+CIE AG, LANGENTHAL/CH	• MOTOREX ATF SUPER D-22656 • MOTOREX ATF DEXRON III MC	HANDELSMIJ NOVIOL B.V., NIJMEGEN/NL	• KENDALL ATF DEXRON IID
CALPAM GMBH, ASCHAFFENBURG/D	• PAMATIC FLUID 289 • CALPAMATIC FLUID III F	HOMBERG GMBH+CO KG, WUPPERTAL/D	• HOMBERG-GETRIEBE-FLUID D
CALTEX PETROLEUM CORP., LONDON/GB	• CALTEX ATF-HDA • CALTEX ATF-HDM • CALTEX TEXAMATIC 1278 • CALTEX TEXAMATIC 7045 • CALTEX TEXAMATIC 1205A	IGOL FRANCE, PARIS/F	• IGOL ATF 420
CASTROL LTD, SWINDON/GB	• CASTROL TQ-D (22765) • CASTROL TQ DEXRON III F-30520 • CASTROL TRANSMAX S (F-30319) • CASTROL TRANSMAX T (F-30359) • CASTROL TQ-D (21289) • CASTROL ATF 21293	INA RAFINERIJA ZAGREB/CROATIA	• INA-ATF SUPER
CEPSA, MADRID/E	• CEPSA ATF-70	ITALIANA PETROLI, GENOVA/I	• TRANSMISSION FLUID DX
CHEVRON PRODUCTS CO., RICHMOND/USA	• CHEVRON ATF F-30108	JAPAN ENERGY CORP., TOKYO/JAPAN	• JOMO ATF K
CITGO PETROLEUM CORP., TULSA/USA	• CITGO ATF DEXRON III F-30167	KÄPPLER K., STUTTGART/D	• SELECTOL FLUID GETR.ÖL IID 23
C.J.DIEDERICHS SÖHNE, WUPPERTAL/D	• CIDISOL-HYDR.-FLUID • DEXRON IID	KLÖCKNER ENERGIEHANDEL GMBH, KÖLN/D	• DEUTZ OEL ATF-D
DE OLIEBRON B.V., ZWIJNDRECHT/NL	• ATF DMM • ATF 289	KROON OIL BV, ALMELO/NL	• ATF DEXRON IID • ALMIROL ATF • Q8 AUTO 15 • Q8 AUTO 14 (IID-21677) • Q8 AUTO 14 (IID) • Q8 AUTO 14 (IID-21883)
DEA MINERALÖL AG, HAMBURG/D	• DEAMATIC • DEAFUID 4011 • DEAFUID 3003	LEPRINCE+SIVEKE GMBH, HERFORD/D	• LEPRINXOL FLUID CN
DEUTSCHE SHELL AG, HAMBURG/D	• MAC ATF D-21666	LIQUI MOLY / MEGUIN, ULM/D	• ATF IIE • MEGOL ATF IID
DUCKHAMS OIL, BROMLEY/GB	• UNIMATIC	LUBRICATION ENGIN., FORT WORTH/USA	• AUTOMATIC TRANSMISSION FLUID
ELF LUBRIFIANTS, PARIS/F	• TRANSANTAR DF2 • ANTA 22329 • ELFMATIC G2 22329 • HUILE RENAULT DIESEL • STARMATIC	MAURAN SA, ODARS/F	• INTER OIL INTER MATIC ATF D2
ELFMATIC G3	• TRANSANTAR DF3	MIN.ÖL-RAFFIN, DOLLBERGEN, UETZE/D	• PENNASOL FLUID-GETRÖL TYP PCN
ELLER-MONTAN-COMP., DUISBURG/D	• ELLMO-AUTOMATIK-FLUID 22233	MOBIL OIL, WEDEL/D	• MOBIL ATF 220 D20104 / D21685 • MOBIL ATF F-30107 • MOBIL ATF 220 D21412 / D22187 • MOBIL ATF 220Y (D-21412)
		MOBIL SEKIYU KABUS. KAISHA, TOKYO/J	
		MOL HUNGARIAN OIL, KOMARON/H	• CARRIER ATF
		MORRIS LUBRICANTS, SHREWSBURY/GB	• LIQUIMATIC DII
		NAFTEC, ALGIER/DZ	• TASSILIA
		NANHAI SUPERIOR LUB-OIL, CHINA	• NANHAI ATF (D2)

MANUFACTURER	PRODUCT
NIS-RAFINERIJA NAPTE BEOGRAD/YU	• GALAX MATIC DAC
OEST G. MIN.ÖLWERK, FREUDENSTADT/D	• ATF T 4011
OMEX PETROLEUM PTY, BELLEVUE/AUS	• OMEX ATF DEXRON II
OMV AG, SCHWECHAT/A	• OMV ATF D II (D22427) • OMV ATF III (F-30580)
OPTIMOL ÖLWERKE, HAMBURG/D	• OPTIMOL ATF T 4011
OSWALD KLUTH, BARGFELD-STEGEN/D	• UNIVERSAL ATF-D
PAKELO MOTOR OIL, SAN BONIFACIO/I	• MULTIPURPOSE TRANSM. FLUID IID
PANOLIN AG, MADETSWIL/CH	• PANOLIN ATF MULTI 21996 • PANOLIN ATF DEXRON III
PARS OIL CO., TEHRAN/IR	• PARS ENTEGHAL-E AUTOMATIC OIL
PAZ LUBRICANTS & CHEMICALS, HAIFA/IL	• PAZBO EZF
PENNZOIL PRODUCT COMP., HOUSTON/USA	• PENNZOIL ATF F-30110
PETRO-CANADA, MISSISSAUGA/CDN	• DEXRON III/MERC.ATF (F-30395)
PÉTROLO OFISI A.S., BAKANLIKLAR/TR	• PETROL OFISI ATF II
PETROLEX, KWIDZYN/PL	• VECO MATIC IID
PRINZ-SCHULTE, FRECHEN/D	• AERO-LINE ATF-2 • AERO-LINE ATF-D
REPSOL DISTRIBUCION SA, MADRID/E	• REPSOL MATIC ATF
S.A.E.L, ALCOBENDAS/E	• GULF ATF DII D-22233
SASOL OIL, RANDBURG/ZA	• SASOL ATF DXII
SCHMIERSTOFFRAFFINERIE SALZBERGEN/D	• WINTERSHALL ATF D
SHELL ASEOL AG, BERN/CH	• ASEOL ATF DB UNIVERSAL
SHELL INTERNATIONAL, LONDON/GB	• SHELL DONAX TA (D-21666) • SHELL DONAX TG (F-30358)
SLOVNAFT JS CO, BRATISLAVA/SLO	• MADIT AUTOMATIC
SONOL ISRAEL LTD, HAIFA/IL	• DEXRON 2 D
SOPROGRASA SA, MADRID/E	• SOPRAL 164
STATOIL STAVANGER/N	• TRANSWAY DX III (F-30373) • TRANSWAY DX II

MANUFACTURER	PRODUCT
STL TECNOL, ESCALQUENS/F	• TECNOL TECMATIC D2
SUN OIL COMPANY, AARTSELAAR/B	• SUNAMATIC 149 • SUNAMATIC 153
SUOMEN PETROOLI OY, HAMINA/SF	• TEBOIL FLUID E (F-30301) • TEBOIL FLUID D
SVENSKA STATOIL AB, NYNÄSHAMN/S	• TRANSWAY DX III (F-30373)
TAMOIL LUBES, GENEVA/CH	• TAMOIL ATF II D
TEXACO LUBRICANTS COMP., BEACON/USA	• ATF MERCON / DEXRON III • TEXAMATIC 7045 • TEXAMATIC 4261
TEXACO SERVICES LTD, BRÜSSEL/B	• TEXAMATIC 7080 • TEXTRAN PSM • TEXAMATIC 4011 • TEXAMATIC 4291 • TEXAMATIC 9226
TOTAL RAFFINAGE DISTR., PARIS/F	• TOTAL FLUIDE ATX • TOTAL FLUIDE IID • TOTAL FLUIDE AT 42
TOTAL SOUTH AFRICA, JOHANNESBURG/ZA	• TOTAL FLUIDE ATD
TURBOTANK BÖSCHE BÖDEKER, BREMEN/D	• TURBO UNIV. ATF MERCON 4011
UFANEFTECHIM REFINERY, UFA/RUS	• UFALUB ATF
UNIL DEUTSCHLAND GMBH, BREMEN/D	• UNIL MATIC CN T 4011
VALVOLINE INC., LEXINGTON/USA	• VALVOLINE MULTI-PURPOSE ATF
VALVOLINE INTERNAT., DORDRECHT/NL	• VALVOLINE ATF TYPE D
VEBA OEL AG, GELSENKIRCHEN/D	• MOVARA ATF-GETRIEBEÖL DIID
VEEDOL INTERNATIONAL, SWINDON/GB	• VEEDOL ATF-M (22764) • VEEDOL ATF DEXRON III F-30521 • VEEDOL UNITRANS S PLUS
YACCO SA, ST PIERRE-LES-ELBEUF/F	• YACCO ATF D
ZELLER+GMELIN GMBH&CO, EISLINGEN/D	• DIVINOL FLUID 666



SECTION X: SPARE PARTS LIST AND EXPLOSION DRAWINGS

Valid for: ZF 45C versions 10, 001;
 Valid for: ZF 45C - Walter version 002;
 Valid for: ZF 45C - Toyota versions 11, 003;
 Valid for: ZF 63C versions 07, 001;
 Valid for: ZF 88C version 001;

The ident number is identical with the order number.
 The indicated dimensions and standards are as such **not** enough for ordering parts.
 When ordering spare parts, please state:

- transmission type
- serial number
- item no., Part name, ident no. and quality of parts required
- shipment desired

You will find the transmission type and version on your transmission name plate.

If the type and version indicated differs from that printed in this Manual, the relative Spare Parts List should be ordered from **ZF HURTH MARINE**.

Subject to technical modification.

Name plate

The name plate is mounted to the transmission

Transmission ratio propeller rotation same to a engine rotation.
Rapporto di trasmissione per elica che ruota nella stessa direzione del motore.

Transmission Serial Number.
Numero di serie dell'invertitore.

Every year a new progressive letter is assigned.
Ogni anno è assegnata una diversa lettera progressiva.

		ZF HURTH MARINE ARCO ITALY	
MODEL	ZF 45 C		
RATIO I	ⁱ A= 1.00	ⁱ B= 1.03	
RATIO II	ⁱ A=	ⁱ B=	
S N - P N	XXXXXL	3311000(001)	

Transmission Type.
Tipo di invertitore.

Transmission ratio propeller rotation opposite engine rotation.
Rapporto di trasmissione per elica che ruota in direzione opposta a quella del motore.

Transmission version.
Versione della trasmissione.

Transmission part number.
Codice della trasmissione.

Pos.	Descrizione	Description	Part. N°.	Old P/N	Q.ty	Note
1	Paraolio entrata	Input shaft seal	3312 301 030	413883	1	
1	Paraolio entrata ZF 45 C Toyota	Input shaft seal ZF 45 C Toyota	0634 311 025	501151	1	
2	Paraolio uscita	Output shaft seal	0634 319 136	500064	1	
2	Paraolio uscita ZF 45 C Toyota	Output shaft seal ZF 45 C Toyota	0634 319 140	501709	1	
3	Filtro olio	Oil filter	3311 301 001	500149	1	
4	Guarnizione	Seal	3311 301 011	500216	1	
5	Coperchietto filtro	Filter cover plate	3311 301 010	500153	1	
6	Vite T.E.	Hex head bolt	0636 015 257	330796	8	
7	Vite T.E.	Hex head bolt	0636 010 375	337982	3	< up to s/n 26637C
7	Vite T.E.	Hex head bolt	0636 010 471	500755	3	> from s/n 26638C
7	Vite T.E.	Hex head bolt	0636 015 257	330796	2	< up to s/n 26637C
7	Vite T.E.	Hex head bolt	0636 010 471	500755	2	> from s/n 26638C
8	Vite T.E.	Hex head bolt	0636 010 375	337982	1	
9	Dado	Nut	0637 006 157	455785	1	
10	Rosetta	Washer	0630 302 090	442372	15	
10a	Guarnizione OR	O-Ring	001.105.0374	500411	2	< up to s/n 16407B
11	Vite	Bolt	0636 103 204	500113	1	
12	Tappo	Plug	0636 309 007	455756	1	
13	Rosetta	Washer	0634 801 302	107410	2	
14	Tappo	Plug	0636 302 053	103465	1	< up to s/n 26637C
14	Tappo	Plug	0636 302 068	500744	1	> from to s/n 26638C
15	Interruttore completo	Neutral safety switch	3312 308 029	455764	1	
16	Distanziale	Spacer	3312 308 039	500030	1	
17	Vite di fermo	Stop bolt	3311 308 002	500201	1	
18	Vite di guida	Guide bolt	3311 308 004	500184	1	
19	Rosetta	Washer	0634 801 302	107410	1	< up to s/n 26637C
19	Rosetta	Washer	0634 801 260	500897	1	> from s/n 26638C
20	Molla	Spring	3312 308 047	500044	1	
21	Sfera	Ball	0635 460 014	106695	2	
22	Sfiato	Breather	3311 301 002	442369	1	
23	Guarnizione	Seal	0634 309 621	500065	1	
24	Compressivo canotto ZF 45 C	Spool valve complete ZF 45 C	3311 208 001	500057	1	< up to s/n 26637C
24	Compressivo canotto ZF 45 C	Spool valve complete ZF 45 C	978.47.600.02	500937	1	< s/n 26638C and s/n 13565E
24	Compressivo canotto ZF 45 C	Spool valve complete ZF 45 C	3311 208 001	500057	1	> from s/n 13566E
24	Compressivo canotto ZF 63 C	Spool valve complete ZF 63 C	3312 208 008	501507	1	
24	Compressivo canotto ZF 88 C	Spool valve complete ZF 88 C	3312 108 023	501400	1	
25	Leva	Shift Lever	3312 308 025	452963	1	
26	Astina olio (senza OR pos. 27)	Oil dipstick (no O-Ring pos. 27)	978.46.700.01	500186	1	< up to s/n 12744F
26	Astina olio con OR pos. 27	Oil dipstick with O-Ring pos. 27	3311 201 001	500994	1	> from s/n 12745F
26	Astina olio per ZF 45 C Toyota	Oil dipstick for ZF 45 C Toyota	3311 201 002	501795	1	O-Ring pos. 27 included
27	Guarnizione OR	O-Ring	0634 304 405	501211	1	
28	Chiavetta pompa	Pump key	978.47.038.01	500410	1	< up to s/n 14311E
28	Chiavetta pompa	Pump key	3311 306 001	500894	1	> from s/n 14312E
29	Carter	Carter	3311 301 008	500162	1	
29	Carter ZF 45 C Toyota	Carter ZF 45 C Toyota	3311 301 015	501815	1	
30	Carter ZF 45 C Toyota	Carter ZF 45 C Toyota	3311 301 013	501813	1	
31	Carter ZF 45 C Toyota	Carter ZF 45 C Toyota	3311 301 014	501814	1	
32	Distanziale per carter ZF 45 C Toyota	Spacer for carter ZF 45 C Toyota	3311 301 016	501794	1	
33	Guarnizione OR	O-Ring	0634 306 300	500073	2	
34	Kit pompa olio	Oil pump kit	3311 199 038	500442	1	
35	Kit coperchio	Cover kit	3311 199 039	500441	1	
36	Scatola	Housing	3311 301 023	500904	1	

Pos.	Descrizione	Description	Part. N°.	Old P/N	Q.ty	Note
37	Albero ingresso completo per ZF 45 C / ZF 63 C	Input shaft assembly for ZF 45 C / ZF 63 C	3311 199 040	500444	1	
37	Albero ingresso completo per ZF 88 C	Input shaft assembly for ZF 88 C	3313 199 006	-	1	
38	Kit portasatelliti	Planetary gear assembly	3311 199 041	500443	1	
39	Anello di tenuta	Piston ring	0634 402 175	500068	3	
40	Anello di tenuta	Piston ring	0634 402 563	500067	2	
41	Cuscinetto a rullini	Needle bearing	0635 303 058	500090	1	
42	Rondella di rasamento	Thrust Washer	978.47.036.01	500235	1	up to s/n 18783B
42a	Gabbia a rullini	Needle bearing	0635 302 019	500557	1	from s/n 18784B
42b	Rondella di rasamento	Thrust Washer	0635 290 002	500558	2	from s/n 18784B
43	Cuscinetto a sfere	Ball bearing	0635 331 216	500211	1	
44	Anello di sicurezza	Retaining ring	0630 531 227	500559	1	
45	Rondella di rasamento	Thrust Washer	3311 304 019	500060	1	
46	Cuscinetto a strisciamanto	Bushing	3311 304 020	500412	1	
47	Supporto corona dentata ZF 45 C / ZF 63 C	Ring gear support ZF 45 C / ZF 63 C	3311 302 030	500234	1	
47	Supporto corona dentata ZF 88 C	Ring gear support ZF 88 C	3313 302 039	501779	1	
48	Anello seeger	Retaining ring	0630 513 039	500352	1	
49	Corona dentata (Z=65) ZF 45 C / ZF 63 C	Ring gear (Z=65) ZF 45 C / ZF 63 C	3311 302 026	500218	1	
49	Corona dentata ZF 88 C	Ring gear ZF 88 C	3313 302 038	501777	1	
50	Anello seeger	Retaining ring	0630 513 066	455788	1	
51	Pistone ZF 45 C / ZF 63 C	Clutch piston forward ZF 45 C / ZF 63 C	3311 302 031	500275	1	
51	Pistone ZF 88 C	Clutch piston forward ZF 88 C	3313 302 040	501778	1	
52	Guarnizione OR	O-Ring	0634 304 400	500354	1	
53	Guarnizione OR	O-Ring	0634 304 128	500243	1	
54	Molla a tazza	Cup spring	3312 302 015	500148	3	
55	Anello di sicurezza	Retaining ring	0630 501 038	500076	1	
56	Pistone	Clutch piston reverse	3311 301 005	500602	1	
57	Guarnizione OR	O-Ring	0634 304 689	500072	1	
58	Molla	Spring	3311 301 007	500190	4	
59	Disco finale	End disc	3311 302 034	500241	1	
60	Disco frizione interno ZF 45 C / ZF 63 C	Inner clutch disc ZF 45 C / ZF 63 C	3311 302 028	500276	5	
60	Disco frizione interno ZF 88 C	Inner clutch disc ZF 88 C	3311 302 028	500276	6	
61	Disco frizione esterno ZF 45 C / ZF 63 C	Outer clutch disc ZF 45 C / ZF 63 C	3311 302 029	500240	6	
61	Disco frizione esterno ZF 88 C	Outer clutch disc ZF 88 C	3311 302 029	500240	7	
62	Disco frizione	Inner clutch disc reverse	3311 302 027	500177	2	
63	Disco intermedio	Outer clutch disc reverse	3311 301 006	500180	3	
64	Spessore 0,3 mm	Shim 0.3 mm	3311 301 042	500355	1	
65	Spessore 0,5 mm	Shim 0.5 mm	3311 301 043	500356	1	
66	Flangia uscita ZF 45 C	Output flange ZF 45 C	3311 304 017	500232	1	
66	Flangia uscita ZF 63 C / ZF 88 C	Output flange ZF 63 C / ZF 88 C	3311 304 018	500346	1	
67	Cuscinetto a sfere	Ball bearing	0635 341 008	500092	1	
68	Spessore 0,1 mm	Shim 0.1 mm	3205 302 007	-	1	
69	Spessore 0,25 mm	Shim 0.25 mm	3205 302 009	-	1	
70	Anello di sicurezza	Retaining ring	0630 502 039	500082	1	
71	Guarnizione OR	O-Ring	0634 303 314	105559	1	
72	Ghiera	Nut ring	0635 513 037	489305	1	
73	Spessore 0,2 mm	Shim 0.2 mm	0630 004 229	500102	1	
74	Spessore 0,3 mm	Shim 0.3 mm	0630 004 124	500487	1	
75	Spessore 0,1 mm	Shim 0.1 mm	3311 304 027	500488	1	
76	Spessore 0,3 mm	Shim 0.3 mm	3311 304 028	500489	1	

REBUILT KIT P/N 3311 199 032
ZF 45 C (no version 11 Toyota), ZF 63 C

Pos.	Description	Part. N°.	Q.ty
1	Input shaft seal	3312 301 030	1
2	Output shaft seal	0634 319 136	1
3	Fluid filter	3311 301 001	1
4	Seal	3311 301 011	1
10a	O-Ring	001.105.0374	2
13	Washer	0634 801 302	2
19	Washer	0634 801 260	1
21	Ball	0635 460 014	2
27	O-Ring	0634 304 405	1
28	Pump Key	3311 306 001	1
33	O-Ring	0634 306 300	2
39	Piston ring	0634 402 175	3
40	Piston ring	0634 402 563	2
42a	Needle bearing	0635 302 019	1
42b	Thrust washer	0635 290 002	2
44	Retaining ring	0630 531 227	1
45	Thrust washer	3311 304 019	1
46	Bushing	3311 304 020	1
48	Retaining ring	0630 513 039	1
50	Retaining ring	0630 513 066	1
52	O-Ring	0634 304 400	1
53	O-Ring	0634 304 128	1
57	O-Ring	0634 304 689	1
58	Spring	3311 301 007	4
60	Inner clutch disc	3311 302 028	5
61	Outer clutch disc	3311 302 029	6
62	Inner clutch disc Reverse	3311 302 027	2
63	Outer clutch disc Reverse	3311 301 006	3
64	Shim 0,3 mm	3311 301 042	1
65	Shim 0,5 mm	3311 301 043	1
68	Shim 0.1 mm	3205 302 007	1
69	Shim 0.25 mm	3205 302 009	1
70	Retaining ring	0630 502 039	1
71	O-Ring	0634 303 314	1
72	Nut ring	0635 513 037	1
73	Shim 0,2 mm	0630 004 229	1
74	Shim 0,3 mm	0630 004 124	1
75	Shim 0,1 mm	3311 304 027	1
76	Shim 0,3 mm	3311 304 028	1

FORWARD CLUTCH KIT P/N 3311 199 033
ZF 45 C (no version 11 Toyota), ZF 63 C

Pos.	Description	Part. N°.	Q.ty
1	Input shaft seal	3312 301 030	1
10a	O-Ring	001.105.0374	2
33	O-Ring	0634 306 300	2
39	Piston ring	0634 402 175	3
40	Piston ring	0634 402 563	2
52	O-Ring	0634 304 400	1
53	O-Ring	0634 304 128	1
57	O-Ring	0634 304 689	1
60	Inner clutch disc	3311 302 028	5
61	Outer clutch disc	3311 302 029	6
73	Shim 0,2 mm	0630 004 229	1
74	Shim 0,3 mm	0630 004 124	1

REVERSE CLUTCH KIT P/N 3311 199 034
ZF 45 C (no version 11 Toyota), ZF 63 C, ZF 88 C

Pos.	Description	Part. N°.	Q.ty
1	Input shaft seal	0634 311 025	1
10a	O-Ring	001.105.0374	2
33	O-Ring	0634 306 300	2
39	Piston ring	0634 402 175	3
40	Piston ring	0634 402 563	2
52	O-Ring	0634 304 400	1
53	O-Ring	0634 304 128	1
57	O-Ring	0634 304 689	1
62	Inner clutch disc Reverse	3311 302 027	2
63	Outer clutch disc Reverse	3311 301 006	3
64	Shim 0,3 mm	3311 301 042	1
65	Shim 0,5 mm	3311 301 043	1

SEAL KIT P/N 3311 199 035
ZF 45 C (no version 11 Toyota), ZF 63 C, ZF 88 C

Pos.	Description	Part. N°.	Q.ty
1	Input shaft seal	3312 301 030	1
2	Output shaft seal	0634 319 136	1
4	Seal	3311 301 011	1
10a	O-Ring	001.105.0374	2
13	Washer	0634 801 302	2
19	Washer	0634 801 260	1
27	O-Ring	0634 304 405	1
33	O-Ring	0634 306 300	2
52	O-Ring	0634 304 400	1
53	O-Ring	0634 304 128	1
57	O-Ring	0634 304 689	1
71	O-Ring	0634 303 314	1

**REBUILT KIT P/N 3313 199 014
ZF 88 C**

Pos.	Description	Part. N°.	Q.ty
1	Input shaft seal	3312 301 030	1
2	Output shaft seal	0634 319 136	1
3	Fluid filter	3311 301 001	1
4	Seal	3311 301 011	1
10a	O-Ring	001.105.0374	2
13	Washer	0634 801 302	2
19	Washer	0634 801 260	1
21	Ball	0635 460 014	2
27	O-Ring	0634 304 405	1
28	Pump Key	3311 306 001	1
33	O-Ring	0634 306 300	2
39	Piston ring	0634 402 175	3
40	Piston ring	0634 402 563	2
42a	Needle bearing	0635 302 019	1
42b	Thrust washer	0635 290 002	2
44	Retaining ring	0630 531 227	1
45	Thrust washer	3311 304 019	1
46	Bushing	3311 304 020	1
48	Retaining ring	0630 513 039	1
50	Retaining ring	0630 513 066	1
52	O-Ring	0634 304 400	1
53	O-Ring	0634 304 128	1
57	O-Ring	0634 304 689	1
58	Spring	3311 301 007	4
60	Inner clutch disc	3311 302 028	6
61	Outer clutch disc	3311 302 029	7
62	Inner clutch disc reverse	3311 302 027	2
63	Outer clutch disc reverse	3311 301 006	3
64	Shim 0,3 mm	3311 301 042	1
65	Shim 0,5 mm	3311 301 043	1
68	Shim 0.1 mm	3205 302 007	1
69	Shim 0.25 mm	3205 302 009	1
70	Retaining ring	0630 502 039	1
71	O-Ring	0634 303 314	1
72	Nut ring	0635 513 037	1
73	Shim 0,2 mm	0630 004 229	1
74	Shim 0,3 mm	0630 004 124	1
75	Shim 0,1 mm	3311 304 027	1
76	Shim 0,3 mm	3311 304 028	1

**FORWARD CLUTCH KIT P/N 3313 199 015
ZF 88 C**

Pos.	Description	Part. N°.	Q.ty
1	Input shaft seal	3312 301 030	1
10a	O-Ring	001.105.0374	2
33	O-Ring	0634 306 300	2
39	Piston ring	0634 402 175	3
40	Piston ring	0634 402 563	2
52	O-Ring	0634 304 400	1
53	O-Ring	0634 304 128	1
57	O-Ring	0634 304 689	1
60	Inner clutch disc	3311 302 028	6
61	Outer clutch disc	3311 302 029	7
73	Shim 0,2 mm	0630 004 229	1
74	Shim 0,3 mm	0630 004 124	1

**REBUILT KIT P/N 3311 199 001
ZF 45 C Toyota**

Pos.	Description	Part. N°.	Q.ty
1	Input shaft seal	0634 311 025	1
2	Output shaft seal	0634 319 140	1
3	Fluid filter	3311 301 001	1
4	Seal	3311 301 011	1
10a	O-Ring	001.105.0374	2
13	Washer	0634 801 302	2
19	Washer	0634 801 260	1
21	Ball	0635 460 014	2
27	O-Ring	0634 304 405	1
28	Pump Key	3311 306 001	1
33	O-Ring	0634 306 300	2
39	Piston ring	0634 402 175	3
40	Piston ring	0634 402 563	2
42a	Needle bearing	0635 302 019	1
42b	Thrust washer	0635 290 002	2
44	Retaining ring	0630 531 227	1
45	Thrust washer	3311 304 019	1
46	Bushing	3311 304 020	1
48	Retaining ring	0630 513 039	1
50	Retaining ring	0630 513 066	1
52	O-Ring	0634 304 400	1
53	O-Ring	0634 304 128	1
57	O-Ring	0634 304 689	1
58	Spring	3311 301 007	4
60	Inner clutch disc	3311 302 028	5
61	Outer clutch disc	3311 302 029	6
62	Inner clutch disc Reverse	3311 302 027	2
63	Outer clutch disc Reverse	3311 301 006	3
64	Shim 0,3 mm	3311 301 042	1
65	Shim 0,5 mm	3311 301 043	1
70	Retaining ring	0630 502 039	1
71	O-Ring	0634 303 314	1
72	Nut ring	0635 513 037	1
73	Shim 0,2 mm	0630 004 229	1
74	Shim 0,3 mm	0630 004 124	1
75	Shim 0,1 mm	3311 304 027	1
76	Shim 0,3 mm	3311 304 028	1

FORWARD CLUTCH KIT P/N 3311 199 003
ZF 45C TOYOTA

Pos.	Description	Part. N°.	Q.ty
1	Input shaft seal	0634 311 025	1
10a	O-Ring	001.105.0374	2
33	O-Ring	0634 306 300	2
39	Piston ring	0634 402 175	3
40	Piston ring	0634 402 563	2
52	O-Ring	0634 304 400	1
53	O-Ring	0634 304 128	1
57	O-Ring	0634 304 689	1
60	Inner clutch disc	3311 302 028	5
61	Outer clutch disc	3311 302 029	6
73	Shim 0,2 mm	0630 004 229	1
74	Shim 0,3 mm	0630 004 124	1

REVERSE CLUTCH KIT P/N 3311 199 004
ZF 45C TOYOTA

Pos.	Description	Part. N°.	Q.ty
1	Input shaft seal	0634 311 025	1
10a	O-Ring	001.105.0374	2
33	O-Ring	0634 306 300	2
39	Piston ring	0634 402 175	3
40	Piston ring	0634 402 563	2
52	O-Ring	0634 304 400	1
53	O-Ring	0634 304 128	1
57	O-Ring	0634 304 689	1
62	Inner clutch disc Reverse	3311 302 027	2
63	Outer clutch disc Reverse	3311 301 006	3
64	Shim 0,3 mm	3311 301 042	1
65	Shim 0,5 mm	3311 301 043	1

SEAL KIT P/N 3311 199 002
ZF 45C TOYOTA

Pos.	Description	Part. N°.	Q.ty
1	Input shaft seal	0634 311 025	1
2	Output shaft seal	0634 319 140	1
4	Seal	3311 301 011	1
10a	O-Ring	001.105.0374	2
13	Washer	0634 801 302	2
19	Washer	0634 801 260	1
27	O-Ring	0634 304 405	1
33	O-Ring	0634 306 300	2
52	O-Ring	0634 304 400	1
53	O-Ring	0634 304 128	1
57	O-Ring	0634 304 689	1
71	O-Ring	0634 303 314	1

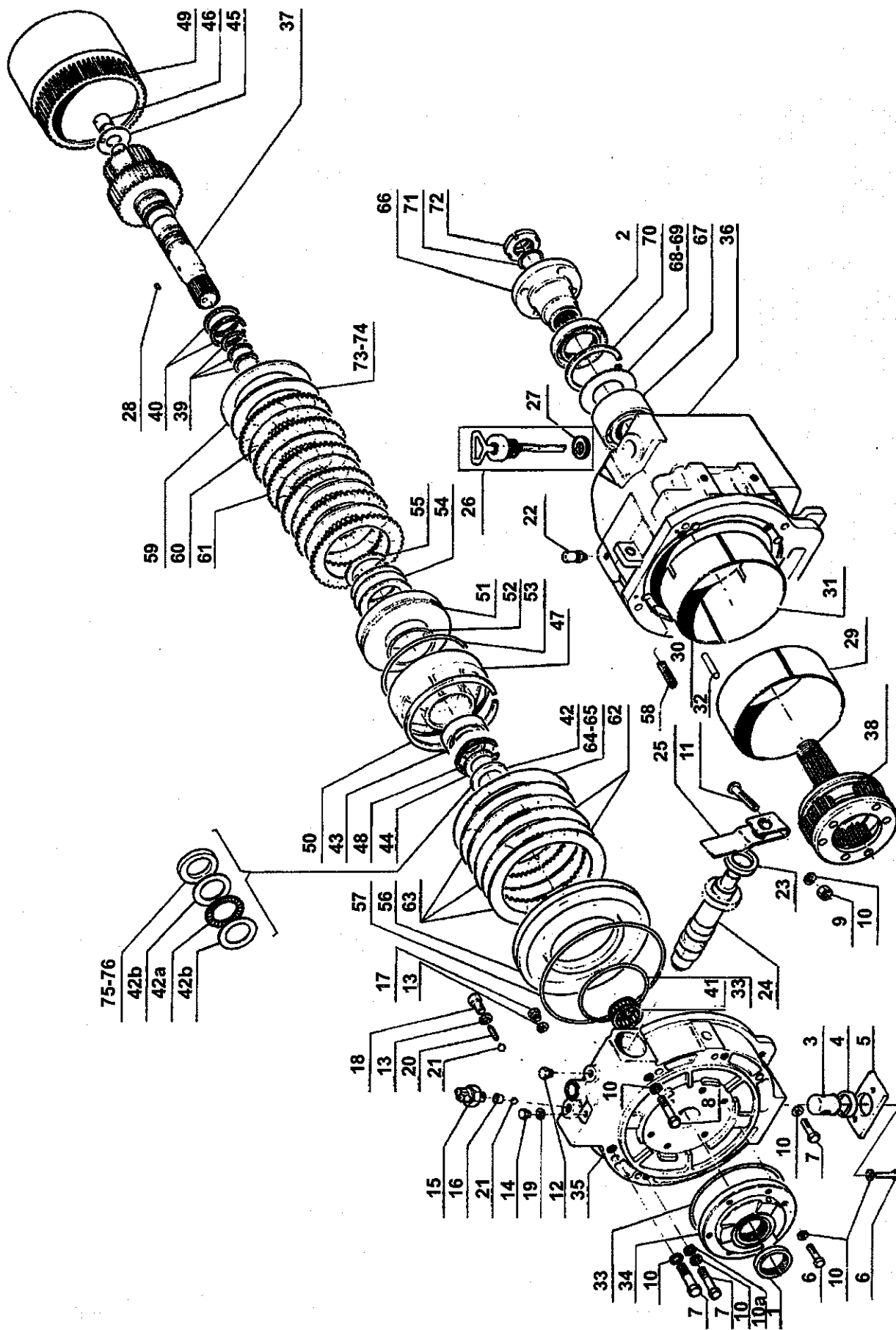



MARINE ZF-HURTH MARINE

ZF Marine GmbH
Ehlerstr. 50
D-88046 Friedrichshafen
GERMANY
Phone +49 (0) 7541 77-2207
Fax +49 (0) 7541 77-4222

ZF Padova S.p.A.
Via Penghe, 48
I-35030 Caselle di Selvazzano
(Padova) ITALY
Phone (+39) 049 8299-311
Fax (+39) 049 8299-550

ZF Hurth Marine S.p.A.
Via S. Andrea, 16
I-38062 Arco
(Trento) ITALY
Phone (+39) 0464 580-555
Fax (+39) 0464 580-544

ZF do BRASIL S.A.
Avenida conde zeppelin 1935
Cep. 18103-000
Sorocaba - SP - BRASIL
Phone +55 (0) 15 235 2586/2389
Fax +55 (0) 15 235 2233